

Assessing online and face-to-face collaboration in a hybrid interdisciplinary course: Analysis of the pertinence of a questionnaire

Audrey Raynault , Sébastien Béland , François Durand , Nicolas Fernandez et Géraldine Heilporn 

Volume 45, numéro spécial, 2022

Translation Issue

URI : <https://id.erudit.org/iderudit/1110993ar>

DOI : <https://doi.org/10.7202/1110993ar>

[Aller au sommaire du numéro](#)

Éditeur(s)

ADMEE-Canada

ISSN

0823-3993 (imprimé)

2368-2000 (numérique)

[Découvrir la revue](#)

Citer cet article

Raynault, A., Béland, S., Durand, F., Fernandez, N. & Heilporn, G. (2022). Assessing online and face-to-face collaboration in a hybrid interdisciplinary course: Analysis of the pertinence of a questionnaire. *Mesure et évaluation en éducation*, 45(spécial), 95–120. <https://doi.org/10.7202/1110993ar>

Résumé de l'article

Des universités offrent des cours d'éducation à la collaboration interprofessionnelle en sciences de la santé et, pour faire face aux défis de synchronisation des horaires, de cloisonnement et de communication, plusieurs sont dispensés en mode hybride. Cet article s'intéresse à l'analyse de la qualité métrique d'un questionnaire utilisé en contexte où des équipes interprofessionnelles ont collaboré en ligne et en présentiel dans le cadre d'un cours universitaire hybride en sciences de la santé. Initialement, ce questionnaire a été conçu pour des personnes du monde du travail dans le but d'évaluer les composantes de la collaboration (communication, synchronisation et coordinations explicite et implicite) mobilisées en présentiel. Les résultats des analyses factorielles confirmatoires de second ordre appuient les qualités métriques du questionnaire original. La collaboration en ligne et en présentiel pourraient être mesurées à l'aide de ce questionnaire dans un cours universitaire hybride. L'étude mobilise des connaissances sur l'évaluation de la collaboration, une voie scientifique peu connue à ce jour.

© Audrey Raynault, Sébastien Béland, François Durand, Nicolas Fernandez et Géraldine Heilporn, 2024



Ce document est protégé par la loi sur le droit d'auteur. L'utilisation des services d'Érudit (y compris la reproduction) est assujettie à sa politique d'utilisation que vous pouvez consulter en ligne.

<https://apropos.erudit.org/fr/usagers/politique-dutilisation/>

Assessing online and face-to-face collaboration in a hybrid interdisciplinary course: analysis of the pertinence of a questionnaire¹

Audrey Raynault

ORCID 0000-0002-5712-0578

Université Laval

Sébastien Béland

ORCID 0000-0002-0324-5076

Université de Montréal

François Durand

ORCID 0000-0002-3660-9411

Université d'Ottawa

Nicolas Fernandez

Université de Montréal

Géraldine Heilporn

ORCID 0000-0002-7951-4420

Université Laval

KEY WORDS: interprofessional education, online collaboration, flipped classroom, assessment instrument, hybrid learning, digital competency, higher education

Universities are offering hybrid interprofessional health sciences collaboration education courses to address the challenges of schedule synchronization, silos, and communication. This article focuses on analyzing the psychometric quality of a questionnaire used in a setting where interprofessional teams collaborated online and face-to-face in a hybrid university health sciences course. This questionnaire was originally designed for people in the working world in order to assess the constructs of collaboration (communication, synchronization and explicit and implicit coordination) mobilized in the face-to-face setting. The results of the second order

1. The French version was published in issue 45(1) 2022: <https://doi.org/10.7202/1097152ar>



confirmatory factor analyses support its use in an academic context and support the metric qualities of the original questionnaire. Online and face-to-face collaboration could be measured using this questionnaire in a hybrid university pedagogical context. The study mobilizes knowledge about the evaluation of collaboration, an avenue that little research has taken to date.

MOTS-CLÉS: collaboration interprofessionnelle, collaboration en ligne, classe inversée, instrument d'évaluation, enseignement hybride, compétence numérique, enseignement supérieur

Des universités offrent des cours d'éducation à la collaboration interprofessionnelle en sciences de la santé et, pour faire face aux défis de synchronisation des horaires, de cloisonnement et de communication, plusieurs sont dispensés en mode hybride. Cet article s'intéresse à l'analyse de la qualité métrique d'un questionnaire utilisé en contexte où des équipes interprofessionnelles ont collaboré en ligne et en présentiel dans le cadre d'un cours universitaire hybride en sciences de la santé. Initialement, ce questionnaire a été conçu pour des personnes du monde du travail dans le but d'évaluer les composantes de la collaboration (communication, synchronisation et coordinations explicite et implicite) mobilisées en présentiel. Les résultats des analyses factorielles confirmatoires de second ordre appuient les qualités métriques du questionnaire original. La collaboration en ligne et en présentiel pourraient être mesurées à l'aide de ce questionnaire dans un cours universitaire hybride. L'étude mobilise des connaissances sur l'évaluation de la collaboration, une voie scientifique peu connue à ce jour.

PALAVRAS-CHAVE: colaboração interprofissional, colaboração online, sala de aula invertida, instrumento de avaliação, ensino híbrido, competência digital, ensino superior

As universidades oferecem cursos de formação em colaboração interprofissional nas ciências da saúde e, para lidar com os desafios de sincronização de horários, compartimentalização e comunicação, vários são oferecidos na modalidade híbrida. Este artigo centra-se na análise da qualidade métrica de um questionário utilizado no contexto em que equipas interprofissionais colaboraram online e presencialmente no âmbito de um curso universitário híbrido de ciências da saúde. Inicialmente, este questionário foi concebido para pessoas do mundo do trabalho com o objetivo de avaliar as componentes da colaboração (comunicação, sincronização e coordenação explícita e implícita) mobilizadas na modalidade presencial. Os resultados das análises fatoriais confirmatórias de segunda ordem apoiam as qualidades métricas do questionário original. A colaboração online e presencial pode ser medida usando este questionário num curso universitário híbrido. O estudo mobiliza conhecimentos sobre a avaliação da colaboração, um caminho científico pouco conhecido até o momento.

Author's note: Please address correspondence regarding this article to audrey.raynault@fse.ulaval.ca.

Introduction

The competency of collaboration has been integrated into professional profiles for over a decade in Canada and the Quebec province, for example in engineering (OIQ, 2005; 2021), health and psychosocial sciences (NAPRA, 2014; CNA, 2011, 2015; CanMEDS, 2005; 2015; CIHC, 2012), and more recently, education (MEES, 2018; 2020). With rising use of digital technology at work and in education, collaboration is recognized to be an essential skill (UNESCO, 2015.).

Research shows that university students benefiting from collaborative learning have higher academic performance, their engagement is more constant, and they have better problem-solving skills in teams than students in more traditional lecture-based courses (Kirschner, 2001; Strelan et al., 2020). Studies into digital-supported collaborative learning have often been conceptual using the computer-supported collaborative learning approach (CSCL), a term coined by O'Malley and Scanlon in 1989. Research by Lipponen (2000) made significant inroads into work on the concept and its methodology. Research into CSCL over the last 30 years has mainly applied experimental methodological approaches spanning from action research to codesign. CSCL research studies digital-supported education using collaboration between learners to improve the learning process and facilitate group learning (Laferrière, 2019). In other words, collaborative learning is underpinned by active pedagogy and prepares future professionals for collaborating in the workplace (UNESCO, 2015; Scott, 2015).

Studies into collaboration at work have also been conducted. Unfortunately, descriptions of the methodologies used in studies to date are insufficient. Also, the conceptual definitions of communication, cooperation, coordination, and collaboration used are often too similar, leading to ambiguity which undermines results (Bedwell et al., 2012). Questionnaires proposed in health care by Accreditation Canada and professional associations assess overall competencies necessary for inter-professional work and collaboration without specifying criteria required for the collaboration process. The study by Chiochio et al. (2012) resulted

in the creation of a questionnaire in French that assesses the components of collaboration based on recommendations by Bedwell et al. (2012). The questionnaire provided proof of validity in interprofessional work situations, in management and health for example, leading to the conceptualization of the interdependent processes of collaboration: communication, synchronicity, implicit coordination, and explicit coordination. Despite scientific proof of the questionnaire's validity at work, we cannot presume this questionnaire is transferable to post-secondary learning.

The purpose of this study is to analyze the quality of the questionnaire's metrics and how the four components function in a university team working both online and face-to-face. We assess the pertinence of the questionnaire as a tool for measuring collaboration in students cocreating and problem-solving online and face-to-face.

The analysis provides evidence confirming that the collaboration construct comprises four components. The results shed light on knowledge about using collaboration processes online and face-to-face for co-creating and problem solving in hybrid university courses. We also make recommendations for future research.

The Problem

Digital Activities and Learning to Collaborate in Interprofessional Education

Universities worldwide offer Interprofessional Education (IPE) programs to teach collaboration in health and social services to prepare future professionals for collaborating in the field (Reeves et al., 2016). For example, Université de Montréal has been offering an IPE program working with patients for over 15 years. It comprises three hybrid courses in collaborative flipped classrooms (Raynault et al., 2020). The purpose is to develop practical skills for collaborating and developing partnerships with patients in health and psychosocial sciences (Barr, 2015; DCP and IOC-UdeM, 2016; Raynault et al., 2020). There are several types of flipped classroom, but generally: (a) most of the reading material and information videos are available for asynchronous learning before classes which are held either synchronously online or face-to-face; (b) time in class or synchronous learning is dedicated to active and social learning activities; and, (c) students are required to work before and/or after class to fully assimilate teamwork and class interactions (Abeysekera & Dawson, 2015).

Research shows that IPE promotes the creation of positive interaction between students from different programs, encourages interprofessional collaboration in clinical settings (Thistlethwaite, 2012), and improves health care and patient safety (Lapkin et al., 2013; Reeves et al., 2016). There are also difficulties in IPE that can hinder collaboration between health professionals which adversely affects patient care (Lawlis et al., 2014). They include the confrontation of different professional biases, inconsistent schedules, and poor communication. IPE must also overcome the logistical challenge of organizing classes of large groups of students from different programs (Reeves et al., 2016). To tackle these issues, Université de Montréal grouped 13 programs which they separated into 800 interprofessional teams to work together on problem-solving and co-creating tasks, initially online. Two months later, their collaboration continued in face-to-face workshops coordinated by a professional and a patient. In this case, a combination of synchronous and asynchronous learning via digital technology were used so team members can work together over a longer period.

The key bodies promoting IPE learning such as the National Center for Interprofessional Practice and Education in the US, the Canadian Interprofessional Health Collaborative in Canada, and the Centre for the Advancement of Interprofessional Education in the UK, recognize that evaluating collaboration in IPE training is a challenge and prompt the research community to study the creation of tools to measure collaboration and other competencies required in interprofessional work.

Digital-supported Collaborative Learning

Using digital technology for collaborative learning is:

an active approach where learners work to build their knowledge facilitated by a trainer or teacher whereas the group motivates and is a source of information, support, and interaction for the co-development of knowledge (Henri & Lundgren-Cayrol, 2001, p. 34)

Grosjean (2004) adds that collaborative learning “requires the virtual copresence of learners and a teacher via synchronous and asynchronous interaction” (p. 2).

Over the last 20 years, researchers have studied different forms of online and face-to-face learning including communities of practice (Wenger, 1998), network learning communities (Bielaczyc & Collins, 1999; Laferrière, 2005; 2019), community of inquiry (Garrison et al.,

2000), knowledge co-development (Scardamalia & Bereiter, 2007), and computer-supported collaborative learning (CSCL) (Laferrière, 2005). These studies drove important developments in learning methods promoting collaborative learning and resulted in recommendations. Teachers should apply particular strategies and adopt certain behavior with a team of students working on collaborative learning tasks, such as problems, cocreating, and conception, synchronously and asynchronously in a digital learning environment. They should (a) provide teams with a supportive framework to teams and propose assessment and self-assessment tools during teamwork; (b) assist students with the technology necessary for working in a team; (c) give clear instructions for completing the collaborative task in advance; and, (d) propose collaborative tasks which require teamwork and interdependency between team members. The proposed tasks should promote interaction between team members, so they solve real problems while co-developing knowledge (Evans et al., 2016; Hei et al., 2016; Jeong & Hmelo-Silver, 2016; Kim et al., 2014; Kirschner, 2001; Laferrière & Resta, 2007; Martin et al., 2012; Scardamalia & Bereiter, 2007; Waterston, 2011).

Collaboration has also been studied in the professional context. For example, work by Chiocchio et al. (2012) resulted in the development of a questionnaire which shows interdependence between four components of collaboration in the workplace: communication, synchronicity, explicit coordination, and implicit coordination, and verified their psychometric properties. Other studies have highlighted the quality of the metrics resulting from the questionnaire in interprofessional contexts (Caniëls et al., 2019; Durand & Fleury, 2021).

Overall, there are insufficient mechanisms and tools to assess collaboration in both learning and professional contexts. Future research should focus on the assessment of collaboration in university education for in-depth and optimal development of this competency in students (Resta et al., 2018; Scott, 2015).

Theoretical Framework

Collaborative Learning to Develop Collaboration Skills

Close links have been shown between deep learning, collaboration, and digital platforms by many cognitive science and sociocultural studies into learning (Bereiter, 2002; Brown, 1994; Bruner, 1978; Rogoff, 1994; Scardamalia & Bereiter, 1994; 2007).

Collaboration also makes it possible to undertake a task, achieve common goals, and reach consensus within a team. It is an evolving process where two or more social entities actively and reciprocally participate in joint activities with a common goal (Bedwell et al. 2012). A process that can evolve, improve, and change over time, collaboration is only possible between social entities working interdependently by contributing sufficiently to a reciprocal interactive process. A complete definition of collaboration requires the presentation of its four components: communication, synchronicity, explicit coordination, and implicit coordination (Chiocchio et al. 2012).

Communication

Chiocchio et al. (2012) began by presenting the communication component in five statements: (a) My teammates and I provide each other with useful information that makes work progress; (b) My teammates and I share knowledge that promotes work progress; (c) My teammates and I understand each other when we talk about the work to be done; (d) My teammates and I share resources that help perform tasks; and, (e) My teammates and I communicate our ideas to each other about the work to be done. The original second-order confirmatory factor analyses (CFAs) defined the structure of the communication component of the collaboration process. The association between the collaboration construct and the communication component is 0.98 and reliability is $\alpha = 0.91$.

Via communication, members can share their ideas freely, listen to and understand each other, and give each other constructive feedback (Chiocchio et al., 2012). Heterogeneous teams find it more difficult than homogeneous teams to share information and exchange knowledge when communicating (Edmondson, 2018). Research by Mesmer-Magnus and Dechurch (2009) revealed an important discrepancy between what teams actually do and what they need to do to optimize effectiveness when performing very complex tasks that generally require experts. Their study

shows that team members communicate and interact more when members already know the information, when they know they are capable of making specific decisions independently, and when the members are similar. Such discrepancies can be explained by pressure to conform, social identity, and relational motivation. On the other hand, effective communication between professionals requires mutual respect and recognition of each other's exclusive contributions; clear, precise, and validated messages; and calm behavior and a supportive demeanor under stress (Robinson et al., 2010).

Communication with Digital Technology

Asynchronous communication on a digital platform for IPE allows for more time for reflection to understand a message and share knowledge, which in turn improves team reflection (Evans et al., 2016). Synchronous online communication also gives interprofessional team members an opportunity to interact, to make informed decisions, and fosters consensus (Hanna et al., 2013). The use of webcams in synchronous collaboration personalizes exchange, improving interaction and decision-making (Martin et al., 2012).

Communication is the transmission mechanism in the collaboration process. Hence, evaluating communication is one way to learn more about how collaboration functions online and face-to-face.

Synchronicity

Chiocchio et al. (2012) presented the synchronicity component of collaboration in three statements: (a) My teammates and I carry out our tasks at the appropriate moment; (b) My teammates and I make sure our tasks are completed on time; and, (c) My teammates and I make adjustments in order to meet deadlines. The original second-order CFAs were used to define synchronicity as a process of collaboration in the tool developed by Chiocchio et al. (2012). The relationship between the collaboration construct and the synchronization component is 0.77 and reliability $\alpha = 0.82$.

It is essential to assess these statements because synchronicity is a process of collaboration which means team members complete their tasks on time, at a particular pace, in accordance with the tasks of others, and respecting a common schedule. In other words, time management (McGrath, 1990).

Synchronicity with Digital Technology

The roll-out of digital technology and tools to enable effective synchronicity was accelerated by lockdowns due to the Covid-19 pandemic. Courville studied how the functions of mobile technology change user action and behavior in his thesis work back in 2017. His results show that using mobile technology for collaborating in interprofessional teams can improve time management and productivity. Synchronicity is a process of collaboration which means team members complete their tasks on time, at a particular pace, in accordance with the tasks of others, and respecting a common schedule, which is time management (McGrath, 1990). In 2022, students can use digital and technological tools to alternate between online synchronous, asynchronous, and face-to-face modes. Assessing synchronicity during online and face-to-face collaboration can teach us more about how team members perform tasks within a deadline.

Explicit and Implicit Coordination

Using the shared mental model (Salas & Fiore, 2004) from the social cognitive approach, Chioocchio et al. (2012) distinguished and defined the processes of explicit and implicit coordination in collaboration. The third component, explicit coordination in the collaboration process is presented with three statements: (a) My teammates and I make progress reports; (b) My teammates and I exchange information on ‘who does what’; and (c) My teammates and I discuss work deadlines with each other. Second-order CFAs were used to define explicit coordination as a process of collaboration. The link between the collaboration construct and the explicit coordination component is 0.86 and reliability $\alpha = 0.78$.

These statements present explicit coordination as a process where team members discuss their roles and the tasks to be performed, which in turn enables them to build knowledge together (Salas & Fiore, 2004). Team members use explicit coordination to exchange information about their contribution to joint tasks (Chioocchio et al., 2012; Salas et al., 2004). For example, teams which effectively share and exchange knowledge about their roles coordinate their actions more smoothly and synchronizing is easier (Kozlowski & Bell, 2003; 2008).

Implicit coordination, the fourth process, is when team members anticipate the needs of other team members and adapt to situations and people without explicit coordination (Chioocchio et al., 2012). Team members use this process to anticipate their teammates’ tasks or needs without exchange

and adapt to arising situations and the people concerned (Chiocchio et al., 2012). Through interaction, the team members' experience of communication improves as their collaboration develops. According to Espinosa et al. (2004), they develop implicit coordination mechanisms, which means they learn to anticipate their colleagues' needs without them being expressed explicitly. Chiocchio et al. (2012) described implicit coordination in three statements: (a) My teammates and I can foresee each other's needs without having to express them; (b) My teammates and I instinctively reorganize our tasks when changes are required; and, (c) My teammates and I have an implicit understanding of the assigned tasks.

The original second-order CFAs made it possible to define explicit coordination as a process of collaboration. The connection between the collaboration construct and implicit coordination component is 0.80 and reliability of scores is $\alpha = 0.78$.

Coordination with Digital Technology

Breen (2013) and Shaffer (2014) showed how effectiveness and performance are improved by teams of students in health sciences when working synchronously via videoconferencing (for example, with Google Hangout, Skype, Messenger, and FaceTime), using online organization tools (such as iCal and Doodle), and collaborative writing tools (such as Google Docs and Word Online). Other online tools combining synchronous and asynchronous modes are also required for logistics and coordination, but synchronous mode seems to be preferable for team coordination. Developing evaluation tools promises to provide clarity about coordination in online and face-to-face collaboration.

Purpose of the Study

The purpose of this study is to collect evidence of the validity and reliability of the questionnaire scores about collaboration during inter-professional teamwork using both online and face-to-face mode in hybrid university programs.

Methodology

Context

A university course where students collaborate interprofessionally with the patient started during the second week of the 2017 winter session. The online course officially began with an email sent to 1,435 students in 13 social and health science programs. It was a six-week course, from mid-January to the end of February. Students were expected to complete four online modules focusing on the following skills: scheduling and providing care and service, clarifying roles, therapeutic education, and preventing and resolving conflict. The interactive models, created in Captivate Adobe, contain videos, quizzes, reading, and clinical scenarios between patients and health professionals working in patient partnerships. They also had to complete two collaborative interprofessional activities online in teams of five students from different programs using a collaborative Google Doc logbook. The teams ($n = 188$) worked online autonomously, with no supervision. These online cocreating and problem-solving activities online were preparation for two other collaborative activities in face-to-face workshops, facilitated by a patient trainer and a health professional. We note that the research team obtained an ethics certificate from the university ethics and research team to conduct this study.

The Questionnaire: Collaboration in Interprofessional Teams

This article is part of a wider doctoral study where a questionnaire with several sections was given to a sample of participants (Raynault, 2020). We asked students to respond to the Collaboration in Interprofessional Teams questionnaire which has three sections. The first two sections of the questionnaire are studied in this article. Section 1 features four demographic questions: gender, curriculum, native language, and team number. Section 2 contains the fourteen statements about the four components of collaboration: communication, synchronicity, explicit coordination and implicit coordination (Chiocchio et al, 2012). A Likert scale of four choices: totally agree, agree, disagree, totally disagree was used to evaluate agreement with each statement both online and face-to-face.

Participants and Procedure

We asked a total of 1,435 students to complete the Collaboration in Interprofessional Teams questionnaire (Raynault, 2020) online using SurveyMonkey at the end of the course, at the end of the academic year in winter 2017. We followed recommendations by Chiochio et Essiembre (2009) to wait at least four weeks for questionnaire responses to allow for team dynamics to settle. A total of 320 people responded: 256 women, 62 men, and 2 people identifying as “other”. They were spread across 13 programs as follows: 9 audiology, 21 occupational therapy, 3 kinesiology, 43 medicine, 20 dentistry, 8 nutrition, 10 optometry, 16 speech therapy, 34 pharmacy, 21 physiotherapy, 2 psychology, 94 nursing, and 40 social work.

Descriptive Statistical Analyses, reliability of scores, and Comparisons

Descriptive statistics were calculated for the items and components. This study adopts Curton’s traditional perspective of validity (1951) that supports the principle whereby validity is the idea that a test measures what it sets out to measure. The t-test for paired samples was used to compare participants with themselves on the components of the collaboration in the two contexts: online and face-to-face. Cohen’s d was used to characterize the size effect: around 0.2 the effect is weak, around 0.5 it is moderate, and it is strong around 0.8.

The chi-square test (χ^2) was used to test the null hypothesis of no relationship between each item, depending on the two contexts: online and face-to-face. The value of Cramer’s V to quantify effect size was added to the analyses. Values between 0 and 1 indicate the extent to which two categorical variables are associated. A value close to zero means that it is very unlikely that the variables are not associated at all in a given population. Finally, the reliability of the scores was estimated using Cronbach’s alpha and McDonald’s omega coefficients. Note the estimation of reliability is satisfactory when the value of the coefficient exceeds 0.7.

Second-order Confirmatory Factor Analyses (CFAs)

Firstly, the second-order confirmatory factor analyses in the study by Chiochio et al. (2012) supported the use of a four-component structure (robust estimators: Satorra-Bentler $\chi^2 = 125.8$, $p < .0001$; NNFI = 0.95; IFI = 0.96; CFI = 0.96; RMSEA = 0.05).

Table 1
*Collaboration component items (Chiocchio et al., 2012)
 used to compare mobilization during online activities (L)
 and the face-to-face interprogram workshop (P)*

Communication	L1/P1 My teammates and I provide each other with useful information that makes work progress.
	L2/P2 My teammates and I share knowledge that promotes work progress.
	L3/P3 My teammates and I understand each other when we talk about the work to be done.
	L4/P4 My teammates and I share resources that help perform tasks.
	L5/P5 My teammates and I communicate our ideas to each other about the work to be done.
Synchronicity	L6/P6 My teammates and I carry out our tasks at the appropriate moment.
	L7/P7 My teammates and I make sure our tasks are completed on time.
	L8/P8 My teammates and I make adjustments in order to meet deadlines.
Explicit Coordination	L9/P9 My teammates and I make progress reports.
	L10/P10 My teammates and I exchange information on 'who does what'.
	L11/P11 My teammates and I discuss work deadlines with each other.
Implicit Coordination	L12/P12 My teammates and I can foresee each others' needs without having to express them.
	L13/P13 My teammates and I instinctively reorganise our tasks when changes are required.
	L14/P14 My teammates and I have an implicit understanding of the assigned tasks.

The second-order CFAs were used to analyze associations between the components and collaboration online, which lasted several weeks, and face-to-face collaboration. The structure was already supported by the theory (Chiocchio et al. 2012) and second-order confirmatory analyses were conducted to confirm this. Maximum likelihood estimation (MLE) of the factorial model was chosen because it presumes multivariate normal distribution. A scale featuring the 14 statements from the questionnaire by

Chiocchio et al. (2012) was reproduced for each of the two contexts: online and face-to-face. The first scale features questions about online collaboration (L) and the second scale applies to face-to-face collaboration (P).

We used 5 fit indices to determine the suitability of the CFA model for the data (Kline, 2016). In the chi-square test, the null hypothesis stipulates that the model fits the data perfectly. It is therefore preferable that the p value exceeds the usual rejection threshold of 0.05 or of 0.01. Second, the comparative fit index (CFI) is acceptable between 0.95 and 1. Third, when the Tucker-Lewis Index (TLI) is between 0.95 and 1, the fit index of the model is very good. Finally, a model is considered acceptable when the mean square error of approximation (RMSEA) is less than 0.08 and the standardized root mean squared residual (SRMR) is less than 0.08 (Kline, 2016).

Results

Descriptive Statistics for each Component of the Collaboration Process Online and Face-to-Face

Statistical analyses using the t -test (Table 2) showed a significant difference between scales for communication, synchronicity, and implicit coordination depending on whether they were online or face-to-face. However, no significant difference was observed between online and face-to-face collaboration for explicit coordination. Cohen's d for the communication scale showed the largest effect size.

The descriptive statistics in Table 3 clearly show the mean (M), most respondents communicated, synchronized, and coordinated explicitly and implicitly whether collaborating with their team online or face-to-face. However, scores for communication, synchronicity, and implicit coordination are slightly higher for face-to-face than online collaboration. The results also show similar standard deviations (SD).

Table 2
Paired sample t-test

Scales	t	p	d
Communication: online (L1-L5) face-to-face (P1-P5)	27.207	0.001	1.533
Synchronicity: online (L6-L8) face-to-face (P6-P8)	-3.737	0.001	-0.211
Explicit coordination: online (L9-L11) face-to-face (P9-P11)	1.620	0.106	0.091
Implicit coordination: online (L12-L14) face-to-face (P12-P14)	-3.138	0.001	-0.177

Most respondents agreed on questions about online communication. The means are between 2.90 and 3.41 and standard deviations between 0.58 and 0.79. For face-to-face, the means are between 2.95 and 3.42 and standard deviations between 0.55 and 0.75. Most students agreed they synchronize when they collaborate online, with means for this component between 3.44 and 3.60 and standard deviations between 0.53 and 0.66. For face-to-face, the means are between 3.59 and 3.64 with standard deviations between 0.49 and 0.51. The descriptive statistical data for explicit coordination is similar to the other two components. For online, the means are between 3.12 and 3.35 and standard deviations between 0.64 and 0.76 which is slightly higher than for face-to-face with means between 3.19 and 3.23 and standard deviations between 0.63 and 0.71. Means between 2.69 and 3.14 and standard deviations between 0.67 and 0.90 indicate that respondents coordinate implicitly when collaborating online team and face-to-face with means between 2.82 and 3.23 and standard deviations between 0.62 and 0.75.

Table 3
Descriptive statistics for each component of the online and face-to-face collaboration process

Items	Collaboration online (L)	Face-to-face collaboration (P)	chi-square χ^2	<i>p</i>	<i>V</i>
L1/P1	M=3.30/SD=0.58	M=3.42/SD=0.58	148.82	< 0.01	0.394
L2/P2	M=3.24/SD=0.62	M=3.36/SD=0.58	225.97	< 0.01	0.486
L3/P3	M=3.24/SD=0.69	M=3.40/SD=0.55	167.47	< 0.01	0.512
L4/P4	M=2.90/SD=0.79	M=2.95/SD=0.75	438.80	< 0.01	0.677
L5/P5	M=3.41/SD=0.60	M=3.40/SD=0.58	145.01	< 0.01	0.475
L6/P6	M=3.44/SD=0.66	M=3.59/SD=0.51	163.75	< 0.01	0.507
L7/P7	M=3.60/SD=0.53	M=3.64/SD=0.49	189.61	< 0.01	0.546
L8/P8	M=3.58/SD=0.56	M=3.61/SD=0.51	204.99	< 0.01	0.569
L9/P9	M=3.12/SD=0.76	M=3.23/SD=0.68	342.17	< 0.01	0.598
L10/P10	M=3.31/SD=0.67	M=3.22/SD=0.63	440.21	< 0.01	0.677
L11/P11	M=3.35/SD=0.64	M=3.19/SD=0.71	205.86	< 0.01	0.464
L12/P12	M=2.69/SD=0.77	M=2.82/SD=0.75	388.24	< 0.01	0.640
L13/P13	M=3.19/SD=0.67	M=3.23/SD=0.62	488.21	< 0.01	0.714
L14/P14	M=3.04/SD=0.90	M=3.08/SD=0.66	225.21	< 0.01	0.487

The chi-square tests are statistically significant with a threshold value of $p < 0.01$. As the null hypothesis is rejected, we note there is a relationship between online and face-to-face collaboration. The Cramer's V results are between 0.394 and 0.714, indicating the association between the variables is moderate to high.

Reliability of scores Analyses

The results of our calculations for online collaboration were Chronbach's alpha = 0.92 and McDonald's omega = 9.2. Face-to-face collaboration results were Cronbach alpha = 0.91 and McDonald's omega = 0.91. Reliability analyses of each component for online and face-to-face collaboration (eight scales) are presented in Table 4. The results show reliability with Chioocchio et al.'s (2012) tool in both cases.

Table 4
Analysis of score reliability for each component for online and face-to-face collaboration (8 scales)

Scales	<i>M</i>	<i>SD</i>	ω	α
Communication online	3.216	0.193	0.841	0.831
Communication face-to-face	3.309	0.202	0.835	0.823
Synchronicity online	3.541	0.086	0.862	0.855
Synchronicity face-to-face	3.611	0.026	0.839	0.836
Explicit coordination online	3.258	0.122	0.815	0.811
Explicit coordination face-to-face	3.212	0.021	0.766	0.765
Implicit coordination online	2.975	0.255	0.769	0.763
Implicit coordination face-to-face	3.042	0.209	0.722	0.713

Second-order confirmatory factor analyses (CFAs)

The p value of the chi-square test for the second-order CFA for online collaboration is <0.05 . The confirmatory fit index (CFI) = 0.965, the Tucker-Lewis index (TLI) = 0.946, SRMR = 0.048, and RMSEA = 0.065. The results show the model is a good fit to the data. The p value of the chi-square test (χ^2) for the second-order CFA for face-to-face collaboration is 0.0001. The CFI = 0.922, TLI = 0.903, SRMR = 0.056 and RMSEA = 0.084. These results slightly exceed usual values but are still acceptable.

The second-order CFAs for both online and face-to-face collaboration show similar saturation with the collaboration construct. Figure 1 shows the results for online collaboration (C-L) (CL-SL-CEL-CIL) and Figure

Figure 1
Second-order CFA results for components of online collaboration

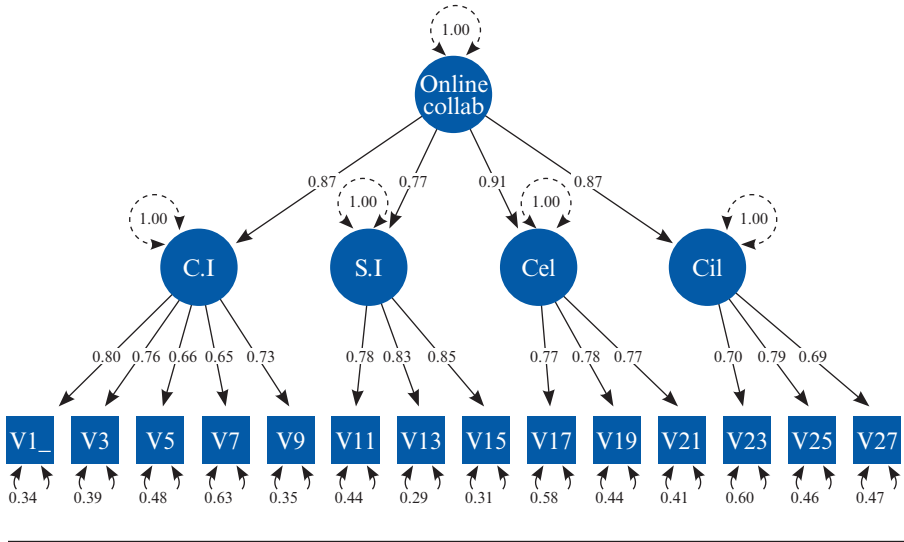
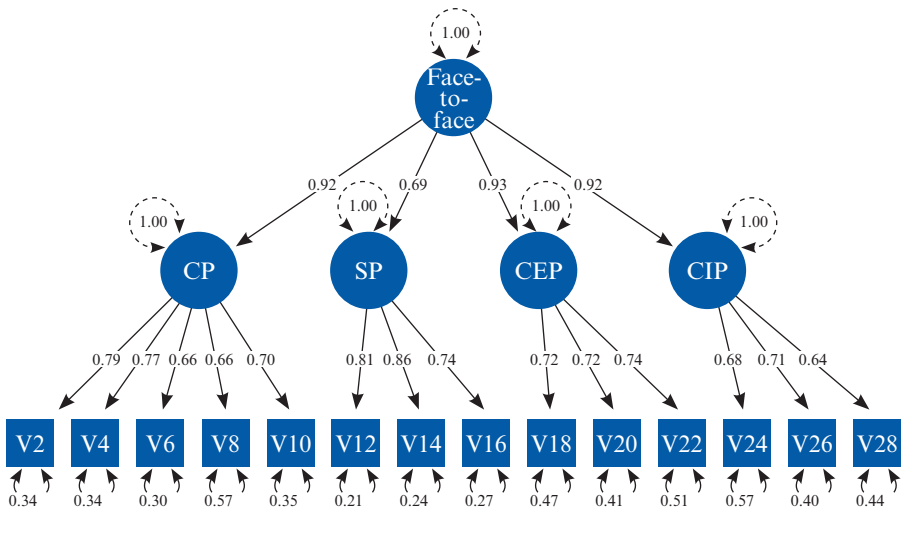

Figure 2
Second-order CFA results for components of face-to-face collaboration



2 for face-to-face collaboration (C-P) (CP-SP-CEP-CIP). In both cases, the explicit coordination component is the highest, at 0.91 for online and 0.93 for face-to-face. The other components are explained similarly for both types of collaboration, but the factor loadings are slightly higher for face-to-face collaboration. The four components also show similar loading coefficients for each statement, but they are slightly higher for online collaboration than face-to-face. The factor loadings are higher for synchronicity in both online and face-to-face collaboration.

Discussion

Our results show the original questionnaire generates quality metrics when applied to interprofessional collaboration in health science university programs using flipped classrooms. The proof of validity of the components (Cureton, 1951) also shows the questionnaire assesses both face-to-face collaboration and online cocreating and problem-solving activities to develop interprofessional collaboration. Chiocchio et al.'s (2012) original questionnaire shows a Cronbach alpha coefficient of $\alpha = 0.92$ which is similar to our findings in this study: $\alpha = 0.92$ and $\alpha = 0.92$ for online collaboration and $\alpha = 0.91$ and $\alpha = 0.91$ for face-to-face collaboration. The chi-square analysis of the items showed a relationship between online and face-to-face collaboration with moderate to large effect size. This shows that the components measure what they are intended to measure with reliability during the collaboration process both online and face-to-face. We are, however, cautious about this interpretation. It would be pertinent to analyze and compare the results of the questionnaire applied in a similar context.

Chiocchio et al.'s (2012) four-component second-order model is a good fit with the context data in this study. The factor loadings between collaboration and the four components and the factor loadings between each of the components and their variables show the model is a good fit with the data.

Relationships Between Each Component and Collaboration

The explicit coordination component is explained by both online (0.91) and face-to-face (0.93) collaboration more than the other components. This shows that the relation is slightly stronger for explicit coordination in face-to-face collaboration than online. Also, between Time 1 (online collaboration) and Time 2 (face-to-face collaboration), factor loading rose

for each component except synchronicity which dropped (online 0.77 and face-to-face 0.69). This may be explained by the context of the study where the teams worked autonomously online and had more supervision when face-to-face. The teams worked together autonomously for two months online and the face-to-face sessions were facilitated by a partnership between a patient and a health professional. After collaborating online for two months, the teams collaborated in face-to-face workshops which possibly required less synchronicity (time management).

More specifically, loading was higher between collaboration and explicit coordination (0.91 versus 0.93) and implicit coordination (0.87 versus 0.92). This supports certain studies into face-to-face collaboration and provides new information about online collaboration. Students were able to work together for a long time in a hybrid context blending online et face-to-face collaboration. For example, Levesque et al. (2001) observed that the more team members interact and acquire expertise related to a common task, the more they learn about the subject of the activity and the other members of the team which can foster implicit coordination between them. Chiocchio et al. (2015) point out that implicit coordination and clear collaboration objectives increase depending on the training. The more teams have common goals, the more they coordinate implicitly. In our study, students collaborated online for over 60 days on cocreating and problem-solving tasks. Two months later, they continued their teamwork on another collaborative activity in a face-to-face workshop. Strengthening relations between collaboration components online and face-to-face collaboration helped students to enhance their explicit and implicit coordination and improve communication which are three of the four components of collaboration according to Chiocchio et al. (2012).

Factor loadings of the Statements for Each Component

The factor loadings for all the statements of each component are slightly higher for online collaboration than face-to-face. This shows that the statements explain their component better for online than face-to-face collaboration. Factor loadings for the synchronicity statements are slightly higher for online collaboration, while all the statements for the three other components show similar loading. Factor loadings for the communication statements are lower for face-to-face collaboration than online.

On this theme, Martin et al. (2012) showed that the use of webcams in synchronous collaboration improves communication and personalizes the process between team members. Research also shows that communication and explicit coordination in asynchronous interaction online for a common task predict team performance (Chiocchio, 2007). Participants in this study spent more time communicating synchronously and asynchronously online to prepare for face-to-face collaboration. The students also mobilized the four components of collaboration when face-to-face under supervision. On the other hand, when online, the teams were autonomous without facilitators. This suggests that the presence of facilitators affects the intensity of interaction.

We are cautious about these results. Further studies are required to clarify in which context students alternated between synchronous and asynchronous modes to communicate online.

At this stage, it is difficult to identify which personality characteristics affect communication, synchronicity, explicit and implicit coordination and how. The second-order model of the four components of collaboration mitigates this problem. How the components impact collaboration in a team is also now clearer for theorists and practitioners (Chiocchio et al., 2012). Our tool, like that developed by Chiocchio et al. (2012), may provide more nuanced predictions about online and face-to-face collaboration.

Methodological Limitations

Chiocchio et al. (2012) initially validated their tool at both the individual and team level to measure collaboration performance in a team at work. They carried out two CFAs: an individual performance analysis and a team performance analysis. When students responded in our study, not necessarily all the members of their team completed the questionnaire. As a result, we only conducted individual CFAs. Collaboration in the teams was not observed. In other words, we did not carry out descriptive and factor analyses by cluster or team. The results of our study are therefore limited to individual performance, offering a representation of collaboration in a work team (Allen & Hecht, 2004; Chiocchio et al., 2012). In some cases, three or four members from the same team responded but it was only the case for six teams out of all 320 respondents. This is a significant methodological limitation for the subject of collaboration as it is ethically impossible to oblige all members of a team to answer a questionnaire

for a study. However, the reliability of the scores and CFAs of our tool shows satisfactory results for both online and face-to-face collaboration, confirming that Chiocchio et al.'s (2012) original tool is transferable to our context.

Conclusion

The factorial structure of this study is consistent with Chiocchio et al. (2012) for learning collaboration in a hybrid health sciences university course for three reasons. First, the reliability of the scores is very similar to that reported by Chiocchio et al. (2012). Second, the results of the second-order CFAs show good fit indexes. The strong relationships between collaboration and its components contribute significantly to online and face-to-face collaboration. The reinforcement of associations between components for online and face-to-face collaboration indicate that collaborating for a longer period of time enabled interprofessional teams to develop and strengthen communication and explicit and implicit coordination. This was less the case for synchronicity. This may be explained by the fact that the teams managed their time autonomously online and had facilitators for the face-to-face sessions. Third, the factor loadings of the statements for each component were significant for both online and face-to-face collaboration, but higher for online. This may be because the teams collaborated for longer online. The results show that the questionnaire measures online and face-to-face collaboration in a hybrid university course where interprofessional teams collaborated on problem-solving and cocreating learning tasks.

Future research would benefit from investigating the quality of collaboration for the team. To that end, we recommend informing participants at the outset that it is important to collect questionnaire responses from several team members. In future studies into collaboration where teamwork begins online and continues face-to-face, we also recommend team members complete the questionnaire at two or three different stages for analysis of the data using a latent growth model.

Received: 15 March 2020

Final Version: 9 June 2022

Accepted: 24 June 2022

REFERENCES

- Abeysekera, L., & Dawson, P. (2015). Motivation and cognitive load in the flipped classroom: Definition, rationale and a call for research. *Higher Education Research & Development, 34*(1), 1-14. <https://doi.org/10.1080/07294360.2014.934336>
- Allen, N. J., & Hecht, T. D. (2004). The romance of teams: Toward an understanding of its psychological underpinnings and implications. *Journal of Occupational and Organizational Psychology, 77*(4), 439-46. <https://doi.org/10.1348/0963179042596469>.
- Association des infirmières et des infirmiers du Canada. (2011). *Énoncé de position: la collaboration interprofessionnelle*. http://cna-aiic.ca/~media/cna/pagecontent/pdf-fr/la-collaboration-interprofessionnelle_enonce-de-position.pdf
- Association des infirmiers et infirmières du Canada (AIIC). (2015). *Cadre de pratique des infirmières et infirmiers du Canada*. <https://www.cnaaiic.ca/~media/cna/page-content/pdf-fr/cadre-de-pratique-des-infirmieres-etinfirmiers-au-canada.pdf?la=fr>
- Association nationale des organismes de réglementation de la pharmacie (ANORP). (2014). *Cadre de référence de compétences professionnelles des pharmaciens au Canada*. http://napra.ca/Content_Files/Files/Comp_PHARMACIENS_canadiens_entreenpratique_FR_Dec2014.pdf
- Barr, H. (2015). *Interprofessional education: The genesis of a global movement*. <https://www.caipe.org/resources/publications/barr-h-2015-interprofessional-education-genesis-global-movement>
- Bedwell, W. L., Wildman, J. L., Diaz Granados, D., Salazar, M., Kramer, W. S., & Salas, E. (2012). Collaboration at work: An integrative multilevel conceptualization. *Human Resource Management Review, 22*(2), 128-145. <https://doi.org/10.1016/j.hrmr.2011.11.007>
- Bereiter, C. (2002). *Education and mind in the knowledge age*. Lawrence Erlbaum Associates.
- Bielaczyc, K., & Collins, A. (1999) Learning communities in classrooms: A reconceptualization of educational practice. Dans C. M. Reigeluth (dir.), *Instructional-design Theories and Models: A New Paradigm of Instructional Theory* (269-292). Lawrence Erlbaum Associates.
- Breen, H. (2013). Virtual collaboration in the online educational setting: A concept analysis. *Nursing Forum, 48*(4), 262-270. <https://doi.org/10.1111/nuf.12034>
- Brown, A. L. (1994). The Advancement of Learning. *Educational Researcher, 23*(8). <https://doi.org/10.3102/0013189X023008004>
- Bruner, J. S. (1978). The role of dialogue in language acquisition. Dans A. Sinclair, R. J. Jarvelle & W. J. M. Levelt (dir.), *The child's concept of language*, (p. 241-256). Springer-Verlag.
- Canadian Interprofessional Health Collaborative (CIHC). (2012). *A national interprofessional competency framework*. University of British Columbia.
- Caniëls, M., Chiocchio, F., & Van Loon, N. (2019). Collaboration in project teams: The role of mastery and performance climates. *International Journal of Project Management, 37*(1), 1-13. <https://doi.org/10.1016/j.ijproman.2018.09.006>
- Chiocchio, F. (2007). Project team performance: a study of electronic task and coordination communication. *Project Management Journal, 8*, 97-109.

- Chiocchio, F., & Essiembre, H. (2009) Cohesion and performance: a meta-analytic review of disparities between project teams, production teams, and service teams, *Small Group Research*, 40, 382–420.
- Chiocchio, F., Grenier, S., O'Neill, T. A., Savaria, K., & Willms, J. D. (2012). The effects of collaboration on performance: A multilevel validation in project teams. *International Journal of Project Organisation and Management*, 4(1), 1-37. <https://doi.org/10.1504/IJPOM.2012.045362>
- Chiocchio, F., Rabbat, F., & Lebel, P. (2015). Multi-level efficacy evidence of a combined interprofessional collaboration and project management training program for healthcare project teams. *Project Management Journal*, 46(4), 20-34.
- Collège royal des médecins et chirurgiens du Canada. (2005). *Le cadre de compétences CanMEDS 2005 pour les médecins*. <https://chirurgie.umontreal.ca/wpcontent/uploads/sites/20/CanMEDS.pdf>
- Collège royal des médecins et chirurgiens du Canada. (2015). *Le cadre de compétences CanMEDS 2015 pour les médecins*. <https://chirurgie.umontreal.ca/wpcontent/uploads/sites/20/CanMEDS.pdf>
- Courville, K. (2017). *How mobile technology impacts interprofessional team-based care in an acute care setting: A realist perspective* [Thèse de doctorat non publiée]. Texas Woman's University. <https://twu-ir.tdl.org/twu-ir/handle/11274/9326>
- Cureton, E. E. (1951). Validity. Dans E. F. Lindquist (dir.), *Educational measurement*, (p. 621-694). American Council on Education.
- Direction collaboration et partenariat patient et Comité interfacultaire opérationnel – Université de Montréal (DCPP-CIOUdeM). (2016). *Référentiel de compétences de la Pratique collaborative et du Partenariat patient en santé et services sociaux*. Université de Montréal.
- Durand, F., & Fleury, M. J. (2021). A multilevel study of patient-centered care perceptions in mental health teams. *BMC Health Services Research*, 21(1), 1-8.
- Edmondson, A. C. (2018). *The fearless organization: Creating psychological safety in the workplace for learning, innovation, and growth*. John Wiley et Sons.
- Espinosa, J. A., Lerch, F. J., & Kraut, R. E. (2004). Explicit versus implicit coordination mechanisms and task dependencies: One size does not fit all. Dans E. Salas & S. M. Fiore (dir.), *Team cognition: understanding the factors the drive process and performance* (p. 107-129). American Psychological Association. <https://doi.org/10.1037/10690-006>
- Evans, S., Shaw, N., Ward, C., & Hayley, A. (2016). Refreshed... reinforced... reflective: A qualitative exploration of interprofessional education facilitators' own interprofessional learning and collaborative practice. *Journal of Interprofessional Care*, 30(6), 702-709. <https://doi.org/10.1080/13561820.2016.1223025>
- Garrison, D. R., Anderson, T., & Archer, W. (2000). Critical inquiry in a text-based environment: Computer conferencing in higher education model. *The Internet and Higher Education*, 2(2-3), 87-105.
- Grosjean, S. (2004). L'apprentissage collaboratif à distance: du scénario pédagogique à la dynamique interactionnelle. Dans Actes du colloque TICE 2004 (p. 229-236). Compiègne, France: Université de Technologie de Compiègne. <http://tecfa.unige.ch/tecfa/teaching/staf11/textes/Grosjean.pdf>
- Hanna, E., Soren, B., Telner, D., MacNeill, H., Lowe, M., & Reeves, S. (2013). Flying blind: The experience of online interprofessional facilitation. *Journal of Interprofessional Care*, 27(4), 298-304. <https://doi.org/10.3109/13561820.2012.723071>

- Hei, M., Strijbos, J. W., Sjoer, E., & Admiraal, W. (2016). Thematic review of approaches to design group learning activities in higher education: The development of a comprehensive framework. *Educational Research Review*, 18, 33-45. <https://doi.org/10.1016/j.edurev.2016.01.001>
- Henri, F., & Lundgren-Cayrol, K. (2001). *Apprentissage collaboratif à distance: pour comprendre et concevoir les environnements d'apprentissage virtuels*. Presses de l'Université du Québec.
- Jeong, H., & Hmelo-Silver, C. E. (2016). Seven affordances of computer-supported collaborative learning: How to support collaborative learning? How can technologies help? *Educational Psychologist*, 51(2), 247-265. <https://doi.org/10.1080/00461520.2016.1158654>
- Kim, M. K., Kim, S. M., Khera, O., & Getman, J. (2014). The experience of three flipped classrooms in an urban university: An exploration of design principles. *The Internet and Higher Education*, 22, 37-50. <https://doi.org/10.1016/j.iheduc.2014.04.003>
- Kirschner, P. A. (2001). Using Integrated Electronic Environments for Collaborative Teaching/Learning. *Learning and Instruction*, 10, 1-9. [http://dx.doi.org/10.1016/S0959-4752\(00\)00021-9](http://dx.doi.org/10.1016/S0959-4752(00)00021-9)
- Kline, R. B. (2016). *Mean structures and latent growth models. Principles and practice of structural equation modeling* (4^e éd.). The Guildford Press.
- Kozlowski, S. J. W., & Bell, B. S. (2003). Work groups and teams in organizations. Dans W. C. Borman, D. R. Ilgen, R. J. Klimoski & I. B. Weiner (dir.), *Handbook of psychology: Industrial and organizational psychology* (Vol. 12, p. 333-375). Wiley.
- Kozlowski, S. W. J., & Bell, B. S. (2008). *Team learning, development, and adaptation*. Dans V. I. Sessa & M. London (dir.), *Group learning* (p. 15-44). LEA.
- Laferrière, T. (2005). Les communautés d'apprenants en réseau au bénéfice de l'éducation. *Encounters in Theory and History of Education*, 6.
- Laferrière, T. (2019). Les effets de l'apprentissage collaboratif supporté par le numérique en milieu scolaire. Dans J.-L. Baron & C. Depover. (dir.), *Les effets du numérique sur l'éducation. Regards sur une saga contemporaine*, 125-141. Presses universitaires du septentrion.
- Lapkin, S., Levett-Jones, T., & Gilligan, C. (2013). A systematic review of the effectiveness of interprofessional education in health professional programs. *Nurse Education Today*, 33(2), 90-102. <https://doi.org/10.1016/j.nedt.2011.11.006>
- Lawlis, T. R., Anson, J., & Greenfield, D. (2014). Barriers and enablers that influence sustainable interprofessional education: A literature review. *Journal of Interprofessional Care*, 28(4), 305-310. <https://doi.org/10.3109/13561820.2014.895977>
- Levesque, L. L., Wilson, J. M., & Wholey, D. R. (2001). Cognitive divergence and shared mental models in software development project teams. *Journal of Organizational Behavior*, 22(2), 135-144. <https://doi.org/10.1002/job.87>
- Lipponen, L. (2000). Towards knowledge building: From facts to explanations in primary students' computer mediated discourse. *Learning Environments Research*, 3(2), 179-199.
- Martin, F., Parker, M., & Deale, D. (2012). Examining interactivity in synchronous virtual classrooms. *International Review of Research in Open and Distance Learning*, 13(3), 227-260. <http://www.irrodl.org/index.php/irrodl/article/view/1174/2253>

- McGrath, J. E. (1990). Time matters in groups. Dans J. Galegher, R. E. Kraut et C. Edigo (dir.), *Intellectual Teamwork: Social and Technological Foundations of cooperative Work*, (p. 23-61). Lawrence Erlbaum Associates, Inc.
- Mesmer-Magnus, J. R., & DeChurch, L. A. (2009). Information sharing and team performance: a meta-analysis. *Journal of Applied Psychology*, 94(2), 535.
- Ministère de l'Éducation et de l'Enseignement supérieur. (2018). *Plan d'action numérique en éducation et en enseignement supérieur*. Gouvernement du Québec. http://www.education.gouv.qc.ca/fileadmin/site_web/documents/ministere/PAN_Plan_action_VF.pdf
- Ministère de l'Éducation et de l'Enseignement supérieur. (2020). *Continuum du développement de la compétence numérique en éducation et en enseignement supérieur*. Gouvernement du Québec. http://www.education.gouv.qc.ca/fileadmin/site_web/documents/ministere/continuum-cadre-reference-num.pdf
- O'Malley, C. E. & Scanlon, E. (1990). Computer-supported collaborative learning: Problem solving and distance education. *Computer Assisted Learning*, 127-136. Pergamon.
- Ordre des ingénieurs du Québec (2021). *Cadre de référence des compétences professionnelles de l'ingénieur*. <http://www.oiq.qc.ca/fr/jeSuis/membre/developpementProfessionnel/Pages/referentieldecompetencesprofessionnelles.aspx>
- Raynault, A. (2020). *Apprendre à collaborer en équipe interprofessionnelle et à développer les compétences de la pratique collaborative et de partenariat patient en santé et services sociaux dans un cours universitaire hybride à l'ère du numérique* [Thèse de doctorat non publiée]. Université de Montréal.
- Raynault, A., Lebel, P., Brault, I., Vanier, M. C., & Flora, L. (2020). How interprofessional teams of students mobilized collaborative practice competencies and the patient partnership approach in a hybrid IPE course. *Journal of Interprofessional Care*, 35(4), 574-585.
- Reeves, S., Fletcher, S., Barr, H., Birch, I., Boet, S., Davies, N., & Kitto, S. (2016). A BEME systematic review of the effects of interprofessional education: BEME Guide n° 39. *Medical Teacher*, 38(7), 656-668. <https://doi.org/10.3109/0142159X.2016.1173663>
- Rentsch, J. R., Delise, L. A., & Hutchison, S. (2009). Cognitive similarity configurations in teams: In search of the Team MindMeld. Dans E. Salas, G. G. Goodwin et C. S. Burke (dir.), *Team effectiveness in complex organizations* (p. 241-266). Routledge.
- Resta, P., & Laferrière, T. (2007). Technology in support of collaborative learning. *Educational Psychology Review*, 19(1), 65-83. <https://doi.org/10.1007/s10648-007-9042-7>
- Resta, P., Laferrière, T., McLaughlin, R., & Kourago, A. (2018). *Issues and challenges related to digital equity: An overview. Second international handbook of information technology in primary and secondary education*. Springer.
- Robinson, F. P., Gorman, G., Slimmer, L. W., & Yudkowsky, R. (2010). Perceptions of effective and ineffective nurse-physician communication in hospitals. *Nursing Forum*, 45(3), 206-216. <https://doi.org/10.1111/j.1744-6198.2010.00182.x>
- Rogoff, B. (1994). Developing Understanding of the Idea of Communities of Learners. *Mind, Culture, and Activity*, 1(4), 209-229.
- Salas, E., & Fiore, S. M. (2004). *Team Cognition: Understanding the Factors that Drive Process and Performance*. American Psychological Association.

- Salas, E., Stagl, K. C., & Burke, S. (2004). 25 years of team effectiveness in organization: research themes and emerging needs. *International review on Industrial and Organisational Psychology*, 19, 47-91.
- Scardamalia, M., & Bereiter, C. (1994). Computer support for knowledge-building communities. *The Journal of the Learning Sciences*, 3(3), 265-283.
- Scardamalia, M., & Bereiter C. (2007). Fostering communities of learners and a knowledge building: An interrupted dialogue. Dans J. C. Campione, K. E. Metz et A. S. Palincsar (dir.), *Children's learning in the laboratory and in the classroom: Essays in honor of Ann Brown*, (p. 97-212). Erlbaum.
- Scott, C. L. (2015). Les apprentissages de demain 2: quel type d'apprentissage pour le XXI^e siècle? *Recherche et prospective en éducation*, 14. <http://unesdoc.unesco.org/images/0024/002429/242996F.pdf>
- Shaffer, K. M. (2014). *Enhancing interprofessional education with technology* [Thèse de doctorat non publiée]. University of Delaware. <http://udspace.udel.edu/handle/19716/16821>
- Strelan, P., Osborn, A., & Palmer, E. (2020). Student satisfaction with courses and instructors in a flipped classroom: A meta-analysis. *Journal of Computer Assisted Learning*. <https://doi.org/10.1111/jcal.12421>
- Strelan, P., Osborn, A., & Palmer, E. (2020). The flipped classroom: A meta-analysis of effects on student performance across disciplines and education levels. *Educational Research Review*, 30(6), 100-314. <http://dx.doi.org/10.1016/j.edurev.2020.100314>
- Thistlethwaite, J. E. (2012). Interprofessional education: A review of context, learning and the research agenda. *Medical Education*, 46(1), 58-70. <https://doi.org/10.1111/j.1365-2923.2011.04143>
- UNESCO. (2015). Référentiel de compétences de l'UNESCO. https://fr.unesco.org/sites/default/files/competency_framework_f.pdf
- Waterston, R. (2011). Interaction in online interprofessional education case discussions. *Journal of Interprofessional Care*, 25(4), 272-279. <https://doi.org/10.3109/13561820.2011.566647>
- Wenger, E. (1998). *Communities of practice. Learning, meaning, and identity*. Cambridge University Press.