

Self-Similarity and Compositional Strategies in the Music of Milton Babbitt

John Cuciurean

Volume 17, Number 2, 1997

URI: <https://id.erudit.org/iderudit/1014783ar>

DOI: <https://doi.org/10.7202/1014783ar>

[See table of contents](#)

Publisher(s)

Canadian University Music Society / Société de musique des universités canadiennes

ISSN

0710-0353 (print)

2291-2436 (digital)

[Explore this journal](#)

Cite this article

Cuciurean, J. (1997). Self-Similarity and Compositional Strategies in the Music of Milton Babbitt. *Canadian University Music Review / Revue de musique des universités canadiennes*, 17(2), 1–16. <https://doi.org/10.7202/1014783ar>

Article abstract

The unfolding of a compact algebraic group into a larger structure which exhibits an isomorphic relationship with the smaller group is the essence of "self-similarity." Through the use of transformational networks which take advantage of the group properties of the forty-eight canonical operators and through the examination of the hexachordally combinatorial properties of Babbitt's row forms, this paper examines the manner in which Babbitt selects and combines rows to produce maximal diversity on the surface while optimizing internal coherence at the deeper structural levels. This study focuses on three works that cover straightforward serial structures, simple array structures and superarray structures respectively — Babbitt's three main compositional strategies.

SELF-SIMILARITY AND COMPOSITIONAL STRATEGIES IN THE MUSIC OF MILTON BABBITT

John Cuciurean¹

There would seem to be a justifiable expectation that composition in the twelve-tone system would employ explicitly formalistic procedures to a greater extent than triadic composition, not only because of the closed, symmetrical nature of the pre-compositional materials of the system, and the fact that the unit of definition (the set) defines a unique set of relationships for each work, but, above all, because of the lack, in the twelve-tone system, of the procedures of functional harmony. ... Thus, instead of a formalistic result, twelve-tone composition would seem to require a predetermined formalistic means.² (Milton Babbitt, 1946)

The preceding quotation, taken from the fifth section of his doctoral dissertation, reveals Babbitt's philosophy for formal implications of set structure in twelve-tone music. In the ensuing forty pages, the thirty-year-old composer intuitively described a compositional approach to large-scale form that would guide his musical thought for the next half century. Babbitt's first works to incorporate the compositional strategies outlined in his dissertation were entitled *Three Compositions for Piano* (1947), *Composition for Four Instruments* (1948), *Composition for Twelve Instruments* (1948/revised 1954), and *Composition for Viola* (1950). In view of Babbitt's attitude towards how mathematics effects twelve-tone procedures, the term "composition" in the titles of these early works probably is meant to suggest its algebraic meaning, that is, as one of the fundamental concepts of group theory.³

¹ A version of this paper was presented at the Canadian University Music Society's annual meeting on 31 May 1996 at Brock University, St. Catharines, Ontario, Canada. I would like to convey my appreciation to Martha Hyde, Jonathan Kochavi, Catherine Nolan, and Andrew Mead for reading through earlier drafts of this paper and providing numerous insightful comments and helpful suggestions.

² Milton Babbitt, "The Function of Set Structure in the Twelve-Tone System" (Ph.D. diss., Princeton University, 1946/1992), 153–54.

³ Since these first works, Babbitt has used "composition" in the titles of three additional works: *Composition for Tenor and Six Instruments* (1960); *Composition for Synthesizer* (1961); and *Composition for Guitar* (1984). Always quick with a pun, Babbitt's titles frequently evoke multiple meanings which often have humorous associations. For instance, *Semi-simple Variations* (1956), *Sextets* (1966) and *The Joy of More Sextets* (1986) both for violin and piano, *My Complements to Roger* (1978), *About Time* (1982), *Four Play* for four players (1984), *It Takes Twelve to Tango* (1984), *Whirled Series* (1987), or *Around the Horn* for solo horn (1993) to cite but a handful. The multiplicity of meaning inherent in his titles is carried over into his compositional approach.

In a number of published interviews, Babbitt, who presents himself as a self-confessed maximalist, describes his aesthetic belief that just as in tonal music, every musical event in post-tonal music should have multiple functions. Beginning with his early works, Babbitt's compositional strategies reveal rich and complex formal procedures, yet his theoretical writings on serial music are frequently elliptical and fail to reveal a clear foundation for investigating the deeper structural levels that form his music. On the other hand, the analyses of individual pieces by scholars such as Joseph Dubiel, William Lake, David Lewin, Andrew Mead, Robert Morris and Brian Alegant, and John Peel and Cheryl Cramer have gone far towards establishing a foundation for an informed theory of deep-level structure.⁴ These analyses as a group provide a basis for this paper's topic, which is to explore in Babbitt's music the relationship between the group properties of set structure and implied musical form at deeper structural levels.

In "Twelve-Tone Invariants as Compositional Determinants," Babbitt outlines the mathematical group properties of the four transformational operators P, I, R, RI.⁵ I would like to review the concepts of group theory that are pertinent to my paper before discussing Babbitt's music. My reasons for this will become clear during the course of my discussion. (For a more detailed summary of my notational conventions, including the formal definitions of group theory and analytic terminology used throughout the essay, please refer to the appendix at the end of this article.)

Briefly, a mathematical group consists of a non-empty set of abstract objects, and a binary operator defined on the set of objects which have four properties: closure, associativity, identity, and inverse. Our usual model of pitch-class space (henceforth, pc space) is a cyclic group Z_{12} which consists of the set of the integers $\{0, 1, \dots, 11\}$ together with the binary operation of mod 12 addition. The direct product of the dihedral group D_2 , which is comprised of the four classical serial operators $\{T, I, R, RI\}$, and the cyclic group Z_{12} which models pc space produces the forty-eight canonical operators — a direct product group which yields a homomorphic image of $Z_{12} \times D_2$. (See definitions 2, 3, and 4 in the appendix.)

The parallel relationship shared between the structural characteristics of a parent group and one of its semi-groups is the essence of "self-similarity." The

⁴ Joseph Dubiel, "Three Essays on Milton Babbitt – Part One: Introduction, Thick Array of Depth Immeasurable," *Perspectives of New Music* 28, no. 2 (1990): 216–61; William Lake, "The Architecture of a Superarray Composition: Milton Babbitt's *String Quartet No. 5*," *Perspectives of New Music* 24, no. 2 (1986): 88–111; David Lewin, "Generalized Interval Systems for Babbitt's Lists and for Schoenberg's String Trio," *Music Theory Spectrum* 17, no. 1 (1995): 81–118; Andrew Mead, "Detail and the Array in Milton Babbitt's *My Complements to Roger*," *Music Theory Spectrum* 5 (1983): 89–109; Andrew Mead, "Recent Developments in the Music of Milton Babbitt," *Musical Quarterly* 70, no. 3 (1984): 310–31; Andrew Mead, *An Introduction to the Music of Milton Babbitt* (NJ: Princeton University Press, 1994); Robert Morris and Brian Alegant, "The Even Partitions in Twelve-Tone Music," *Music Theory Spectrum* 10 (1988): 74–101; and John Peel and Cheryl Cramer, "Correspondences and Associations in Milton Babbitt's *Reflections*," *Perspectives of New Music* 24, no. 2 (1986): 144–207.

⁵ Milton Babbitt, "Twelve-Tone Invariants as Compositional Determinants," *The Musical Quarterly* 46, no. 2 (1960): 246–59.

concepts of self-similarity are used in mathematics and physics to describe the geometry of crystalline structures and serve as the basis for fractal imaging, yet few music theorists have explored self-similarity as a basis for structural-level analysis of musical form.⁶ The concept of self-similarity is one manifestation of the subset invariance theorem. Applying this theorem to a subgroup of the four (of forty-eight) canonical operators that map a type A, B, C, or E⁷ hexachordally combinatorial row form to a row form which maintains hexachordal-invariance produces the results shown in table 1:⁸

	T_0	I_{n+6}	R_6	RI_n
T_0	T_0	I_{n+6}	R_6	RI_n
I_{n+6}	I_{n+6}	T_0	RI_n	R_6
R_6	R_6	RI_n	T_0	I_{n+6}
RI_n	RI_n	R_6	I_{n+6}	T_0

Table 1: The direct product of the four classical serial operators, T, I, R, RI.

$\{T_0, I_{n+6}, R_6, RI_n\} \cong D_2$ is a subgroup of $Z_{12} \times D_2$, which holds hexachordal pc content invariant for type A hexachords at $n=1$, type B at $n=1$, type C at $n=3$ and type E at $n=3, 7, 11$.⁹ (Also note that if we wish to examine hexachordal combinatorial relationships rather than hexachordal pc invariance relationships, all that is required is to re-map the subgroup $\{T_0, I_{n+6}, R_6, RI_n\}$ via the

⁶Some may argue that Schenker's notion of motivic parallelism (as discussed in Charles Burkhart, "Schenker's 'Motivic Parallelisms'," *Journal of Music Theory* 22, no. 2 (1978): 145-75; and elsewhere) on the various structural levels — especially between surface gestures and the *Uralinie* — constitute analysis of self-similar properties. Analogously, I use the English terms foreground, middleground, and background when discussing Babbitt's structural levels, but my analysis focuses on direct mathematical isomorphisms and it is at this juncture that the philosophical basis of Schenker's exploration of self-similar relationships and mine diverge.

⁷Type A, B, C, and E hexachords are defined by Babbitt in "Some Aspects of Twelve-Tone Composition," *The Score and I.M.A. Magazine* 12 (1955): 53-61 as four of the six possible all-combinatorial hexachords; the other two are designated types D and F. For readers more comfortable with Forte set-class labels, types A, B, C, D, E, and F hexachords are equivalent to set-classes 6-1 (012345), 6-8 (023457), 6-32 (024579), 6-7 (012678), 6-20 (014589), and 6-35 (02468t) respectively as given in Allen Forte, *The Structure of Atonal Music* (New Haven: Yale University Press, 1973). Initially I exclude D and F type hexachords from the subset invariance theorem due to the complications introduced by the tritone symmetry inherent in these two hexachords. I will develop and expand the subset invariance theorem latter in this paper to include the type D hexachord. I will not expand the theorem to include the type F "whole-tone" hexachord in this paper since Babbitt avoids this hexachord in his compositional practice.

⁸I am grateful to Larry Fritts for bringing this example to my attention in his paper "The Group Structure of Babbitt's *Three Compositions for Piano*," read at the Music Theory Midwest/Society of Composers Meeting, University of Iowa, 7 April 1995. Discrepancies between our two presentations are a result of different notational approaches to the same problem.

⁹Note that each of these four hexachord types contain a zero entry for interval class 6 in the ic vector which accounts for the R_6 invariance of each. Also note that these n values apply to sets in prime form. The interval-class vector for a type A hexachord is <543210>; type B hexachord is <343230>; type C hexachord is <143250>; and type E hexachords is <303630>.

T_6 operator onto a coset $\{T_6, I_n, R_0, RI_{n+6}\}$, where the respective values of n remain unchanged for each of the four represented hexachord types.)

I propose that the generation of cosets of the forty-eight canonical operators whose membership is contingent upon the hexachordal combinatorial relationships of a row form provides the basis for large-scale structure in Babbitt's music. In the following section I examine how Babbitt selects and combines rows to produce maximal diversity on the surface while insuring maximal internal coherence at the deeper structural levels. My examination focuses exclusively on pitch space, but I see little reason why this same analytic principle could not be extended to the rhythmic domain — indeed, the recent work by Andrew Mead supports this contention by revealing parallels that exist between Babbitt's pitch and rhythmic structures.¹⁰ My investigation took several of Babbitt's pieces into consideration, spanning almost fifty years of compositional practice. In the interest of space, I concentrate on three pieces, *Duet for Solo Piano* (1956), *Reflections for Piano and Tape* (1975), and *Soli e Duettini for Two Guitars* (1989) which together use straightforward serial structures, array structures, and superarray structures respectively.

Babbitt's technical procedures are gradually becoming documented through articles that address both analytical and theoretical issues.¹¹ Most importantly, several published analyses (including those by Dubiel, Lake, Mead, and Peel and Cramer) have focused on the difficult issue of how the composer incorporates pitch-array strategies. My paper investigates the structure of pitch arrays and demonstrates how the hexachordally combinatorial properties of a given row can be used as transformational operators on the structural middleground to produce a complex network of row forms, all of which relate back to the dihedral group properties of the four transformational operators at the background structural-level, while maintaining maximal diversity on the foreground.

Simple Serial Structures

Duet for Solo Piano (1956), which was composed as a gift to his daughter, concisely illustrates Babbitt's strategy for large-scale structural design. The polyphony is based exclusively on a two-voice counterpoint between the pianists right and left hands. The initial row form, $\langle 207954638e1 \rangle$, presented in the right hand beginning at m. 1 derives from a type C all-combinatorial hexachord which is hexachordally combinatorial when integrated with the coset of canonical operators, $\{T_6, I_3, R_0, RI_9\}$: refer back to Table 1. The piece uses the following progression of row forms on its surface or foreground:

<i>Measure no.:</i>	1	6	10	14
Lyne 1 (RH):	P_2	RI_1	I_7	R_8
Lyne 2 (LH):	P_8	R_2	RI_7	I_1

Example 1: Row form array for *Duet*.

¹⁰Andrew Mead, "About *About Time*'s Time: A Survey of Milton Babbitt's Recent Rhythmic Practice," *Perspectives of New Music* 25, nos. 1-2 (1987): 182-235.

¹¹As the list of citations in footnote no. 4 suggests.

We first need to examine the relationships between the eight row forms that structure the piece. The eight row forms, $\{P_2, RI_1, I_7, R_8, P_8, R_2, RI_7, I_1\}$, form a collection which is generated from a single prime-form set P_2 , its T_0 transposition (trivially), its I_3 inversion, their T_6 transpositions and the R_0 retrogrades of all sets derived thus far, shown in equation 1.

$$\text{Eq. 1} \quad \{P_2\} \otimes \{T_0, T_6, I_3, I_9, R_0, R_6, RI_3, RI_9\} \equiv \{P_2, P_8, I_1, I_7, R_2, R_8, RI_1, RI_7\}$$

\otimes denotes an operator whose operands consist of a set of row forms and a set of canonical operators. The operation produces a resultant set of row forms which is comprised of the union of the application of each and every member of the canonical operator set to each and every member of the row form set, in no specific order.

To generalize this from a slightly different perspective, I will call P_8 the hexachordal complement of P_2 , and label $P_8 \equiv P_2-1$, then equation 2, which includes $\{P_2, P_2-1\}$ as the set of row forms and $\{T_6, I_3, R_0, RI_9\}$ as the coset of canonical operators which effect hexachordal combinatoriality for a type C all-combinatorial hexachord, also describes the pc content of this piece.

$$\text{Eq. 2} \quad \{P_2, P_2-1\} \otimes \{T_6, I_3, R_0, RI_9\} \equiv \{P_2, P_8, I_1, I_7, R_2, R_8, RI_1, RI_7\}$$

This equation could also be expressed using the subgroup of operators which hold hexachordal content invariant, shown in equation 3.

$$\text{Eq. 3} \quad \{P_2, P_2-1\} \otimes \{T_0, I_9, R_6, RI_3\} \equiv \{P_2, P_8, I_1, I_7, R_2, R_8, RI_1, RI_7\}$$

Please note that equations 1, 2, and 3 are all equivalent. Furthermore, in each case I chose P_2 as my reference row form, but I could have used any one of the eight representative row forms in the piece as my reference point and produced the same 8 row collection in each case.

Returning to the array of row forms distributed throughout the piece, another important property structures the horizontal relationships between the successive row forms in each hand and the vertical relationships of the simultaneously presented adjacent row forms. The diagram in Example 2 presents a chronological account of the progression of row forms reading left to right and an account of the combinatorially paired row forms reading top to bottom. The large arches that span from start to finish account for the net result of the composite linear operations.¹²

As we might expect, the vertical pairings of row forms consistently take advantage of the coset of combinatorial operators, $\{T_6, I_3, R_0, RI_9\}$. Moreover, and in keeping with Babbitt's edict of maximal diversity, each one of the four operators is used one time only. What seems less predictable, however, is the set of operators acting upon the linear or horizontal transformations of successive row forms. The set of operators that move the piece temporally forward

¹²The network presentation is modelled after Henry Klumpenower, "A Generalized Model of Voice-leading for Atonal Music" (Ph.D. diss., Harvard University, 1991); David Lewin, *Generalized Musical Intervals and Transformations* (New Haven: Yale University Press, 1987); and David Lewin, "Klumpenower Networks and Some Isographies That Involve Them," *Music Theory Spectrum* 12, no. 1 (1990): 83-120.

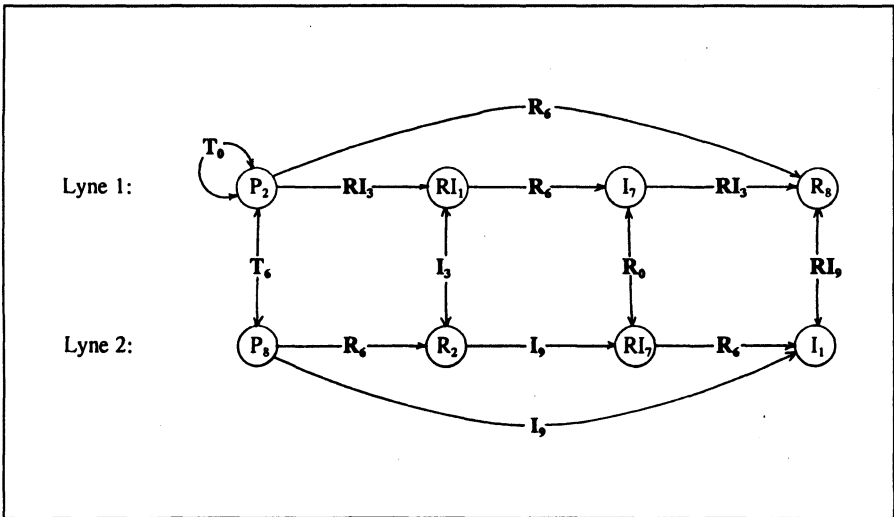

Example 2: Transformational network of pitch structure in *Duet*.

consist of $\{I_9, R_6, RI_3\}$, which if we admit the identity operator T_0 to this set, constitutes the subgroup of operators that maintain pc hexachordal invariance for a type C hexachord, $\{T_0, I_9, R_6, RI_3\}$.

Just as we created a complement relation, $\{P_2, P_2^{-1}\}$, between two distinct row forms, we can define the complement-set of canonical operators to the coset of hexachordally combinatorial operators as abstractly being the subgroup of operators which maintain hexachordal pc invariance. (The formal definition for this equation is included in the appendix, Definition 6.) If $S \equiv \{T_6, I_n, R_0, RI_{n+6}\}$, a coset of $D_2 \times Z_{12}$ that admits hexachordal combinatoriality for type C hexachords at $n=3$, then we shall recognize S^{-1} as given in equation 4 to be a subgroup of $D_2 \times Z_{12}$ that holds hexachordal pc content invariant for type C hexachords at $n=3$.

$$\text{Eq. 4} \quad S^{-1} = T_6(S) \equiv \{T_6, I_n, R_0, RI_{n+6}\}^{-1} \equiv \{T_0, I_{n+6}, R_6, RI_n\}$$

We can now abstractly identify the background structure of this brief composition. By background structure, I simply mean that the entire piece can be represented as the direct product of a single, well defined set of row forms and a subgroup of operators. By beginning with the pitch map at the foreground, shown in Example 3, the algebraic model is developed as the middle- and background levels are successively extracted from the foreground.

The analytic model in Example 3 marries algebraic self-similarity with multi-level structural paradigms, yielding what I believe to be a novel, albeit complex, perspective on an otherwise simple serial piece. Some critics might argue that this analytical approach is comparable to tapping a thumb tack into the wall with a sledge hammer, and perhaps in this simple case such an

$$\begin{aligned}
 & \left(\begin{array}{cccc} 20795463t8e1 & 247509et6831 & 79204536e1t8 & 752490te3168 \\ 8613et094257 & 1e8t36459702 & 8t1e63540297 & 1386te905742 \end{array} \right) & \text{Foreground} \\
 & = \left[\begin{array}{l} (P_2, RI_1, I_7, R_8) \\ (P_8, R_2, RI_7, I_1) \end{array} \right] \\
 & \quad \cdot \{P_2, P_8, I_1, I_7, R_2, R_8, RI_1, RI_7\} & \text{Middleground} \\
 & \quad \cdot \{P_2\} \circ \{T_0, T_6, I_3, I_9, R_0, R_6, RI_3, RI_9\} & \text{(from eq. 1)} \\
 & = \{P_2, P_2^{-1}\} \circ \{T_6, I_3, R_0, RI_9\} & \text{(from eq. 2)} \\
 & = \{P_2, P_2^{-1}\} \circ \{T_0, I_9, R_6, RI_3\} & \text{(from eq. 3)} \\
 & = \{P_2\} \circ [\{T_6, I_3, R_0, RI_9\} \cup \{T_6, I_3, R_0, RI_9\}^{-1}] \\
 & = \{P_2\} \circ [S \cup S^{-1}] & \text{Background}
 \end{aligned}$$

Example 3: Analytic model of *Duet* at successive reductional levels.

argument has some merit. However, its application to *Reflections for Piano and Tape* (1975) suggests that the proverbial thumb tack has developed into a large spike and the analytic apparatus no longer seems quite so extravagant. For convenience, I here use John Peel and Cheryl Cramer's analysis of *Reflections* as my point of departure.¹³

Array Structures

The all-combinatorial properties of the hexachord that structures *Reflections*' type A row are exploited in the construction of the 12-lyne, 6-block, 77-partition, all-partition array which forms the foundation for the piece's pitch structure.¹⁴ The transformational network which generates the foreground pitch-class all-partition array in the first section of the piece (mm. 1–82) is shown in Table 2.

¹³Peel and Cramer, "Correspondences and Associations." I draw primarily upon the chart of row forms that Peel and Cramer present as structuring the surface of the form, given on pp.186–203. Note that wherever they have identified a prime row form as S_n , I have rewritten the label as P_n .

¹⁴Ibid. Babbitt himself first outlined partition array strategies in "Since Schoenberg," *Perspectives of New Music* 12, nos. 1–2 (1974): 3–28, however I refer the reader to the recent writings of Andrew Mead and William Lake for a clearer explication of partition arrays. See for example Andrew Mead, "Detail and the Array"; idem, *An Introduction to the Music of Milton Babbitt* (Princeton, 1994), 124–203; William Lake, "The Architecture of a Superarray."

<u>Block 1</u>	<u>Block 2</u>	<u>Block 3</u>	<u>Block 4</u>	<u>Block 5</u>	<u>Block 6</u>
$\left\{ \begin{array}{l} P_2 \\ I_7 \end{array} \right\}$	$\left\{ \begin{array}{l} RI_7 \\ R_2 \end{array} \right\}$	$\left\{ \begin{array}{l} I_1 \\ P_8 \end{array} \right\}$	$\left\{ \begin{array}{l} R_8 \\ RI_1 \end{array} \right\}$	$\left\{ \begin{array}{l} P_2 \\ I_7 \end{array} \right\}$	$\left\{ \begin{array}{l} RI_7 \\ R_2 \end{array} \right\}$
$\left\{ \begin{array}{l} P_4 \\ I_9 \end{array} \right\}$	$\left\{ \begin{array}{l} RI_9 \\ R_4 \end{array} \right\}$	$\left\{ \begin{array}{l} I_3 \\ P_{10} \end{array} \right\}$	$\left\{ \begin{array}{l} R_{10} \\ RI_3 \end{array} \right\}$	$\left\{ \begin{array}{l} P_4 \\ I_9 \end{array} \right\}$	$\left\{ \begin{array}{l} RI_9 \\ R_4 \end{array} \right\}$
$\left\{ \begin{array}{l} P_0 \\ I_5 \end{array} \right\}$	$\left\{ \begin{array}{l} RI_5 \\ R_0 \end{array} \right\}$	$\left\{ \begin{array}{l} I_{11} \\ P_6 \end{array} \right\}$	$\left\{ \begin{array}{l} R_6 \\ RI_{11} \end{array} \right\}$	$\left\{ \begin{array}{l} P_0 \\ I_5 \end{array} \right\}$	$\left\{ \begin{array}{l} RI_5 \\ R_0 \end{array} \right\}$
$\left\{ \begin{array}{l} RI_2 \\ R_9 \end{array} \right\}$	$\left\{ \begin{array}{l} P_9 \\ I_2 \end{array} \right\}$	$\left\{ \begin{array}{l} R_3 \\ RI_8 \end{array} \right\}$	$\left\{ \begin{array}{l} I_8 \\ P_3 \end{array} \right\}$	$\left\{ \begin{array}{l} RI_2 \\ R_9 \end{array} \right\}$	$\left\{ \begin{array}{l} P_9 \\ I_2 \end{array} \right\}$
$\left\{ \begin{array}{l} RI_4 \\ R_{11} \end{array} \right\}$	$\left\{ \begin{array}{l} P_{11} \\ I_4 \end{array} \right\}$	$\left\{ \begin{array}{l} R_5 \\ RI_{10} \end{array} \right\}$	$\left\{ \begin{array}{l} I_{10} \\ P_5 \end{array} \right\}$	$\left\{ \begin{array}{l} RI_4 \\ R_{11} \end{array} \right\}$	$\left\{ \begin{array}{l} P_{11} \\ I_4 \end{array} \right\}$
$\left\{ \begin{array}{l} RI_0 \\ R_7 \end{array} \right\}$	$\left\{ \begin{array}{l} P_7 \\ I_0 \end{array} \right\}$	$\left\{ \begin{array}{l} R_1 \\ RI_6 \end{array} \right\}$	$\left\{ \begin{array}{l} I_6 \\ P_1 \end{array} \right\}$	$\left\{ \begin{array}{l} RI_0 \\ R_7 \end{array} \right\}$	$\left\{ \begin{array}{l} P_7 \\ I_0 \end{array} \right\}$

Table 2: Row form array for *Reflections* (mm. 1–82).

By the end of the fourth block of the array, all forty-eight forms of the row have appeared once and only once. Blocks 5 and 6 use row forms which have previously appeared in blocks 1 and 2 exclusively. Careful analysis of this network reveals that the lynes of the array are grouped by row pairs that under I_5 are hexachordally combinatorial (indicated with curly brace brackets). These are further related by treating the lower six lynes as an RI_2 transform of the upper six lynes. To carry this network of transformational relationships one level deeper I have labelled the twelve row forms that make up array block 1 as A1 and I have traced the progression of row forms temporally through the array. This resultant network of horizontal transformations is shown in the middleground analysis of Example 4.

<u>Block 1</u>	<u>Block 2</u>	<u>Block 3</u>	<u>Block 4</u>	<u>Block 5</u>	<u>Block 6</u>
$T_0(A1)$	$RI_5(A1)$	$I_{11}(A1)$	$R_6(A1)$	$T_0(A1)$	$RI_5(A1)$

Example 4: Middleground network of array structure in *Reflections* (mm. 1–82).

Returning to the foreground in the second section of the piece (mm. 83–178), the pc array utilizes a different distribution of row forms, as shown in Table 3. The use of all forty-eight row forms by the end of the fourth block is still in place, as are the row pairs that are I_5 hexachordally combinatorial (indicated with curly brace brackets) and the RI_2 relationship between upper and lower six lynes.

<u>Block 1</u>	<u>Block 2</u>	<u>Block 3</u>	<u>Block 4</u>	<u>Block 5</u>	<u>Block 6</u>
R ₀	I ₅	RI ₁₁	P ₆	R ₀	I ₅
RI ₅	P ₀	R ₆	I ₁₁	RI ₅	P ₀
RI ₃	P ₁₀	R ₄	I ₉	RI ₃	P ₁₀
R ₁₀	I ₃	RI ₉	P ₄	R ₁₀	I ₃
RI ₁	P ₈	R ₂	I ₇	RI ₁	P ₈
R ₈	I ₁	RI ₇	P ₂	R ₈	I ₁
I ₈	R ₃	P ₉	RI ₂	I ₈	R ₃
P ₃	RI ₈	I ₂	R ₉	P ₃	RI ₈
I ₁₀	R ₅	P ₁₁	RI ₄	I ₁₀	R ₅
P ₅	RI ₁₀	I ₄	R ₁₁	P ₅	RI ₁₀
I ₆	R ₁	P ₇	RI ₀	I ₆	R ₁
P ₁	RI ₆	I ₀	R ₇	P ₁	RI ₆

Table 3: Row form array for *Reflections* (mm. 83–178).

Returning to the middleground analysis, I have labelled the twelve row forms that comprise block 1 as A2 for this second section of the piece. The resulting network of horizontal transformations is shown in the middleground analysis given in Example 5. Please take a moment to note the homomorphism that characterizes the relationship between the transformational networks of the first and second sections of this work by comparing Examples 4 and 5.

$$\begin{array}{cccccc} \text{Block 1} & \text{Block 2} & \text{Block 3} & \text{Block 4} & \text{Block 5} & \text{Block 6} \\ (T_0(A2), & RI_5(A2), & I_{11}(A2), & R_6(A2), & T_0(A2), & RI_5(A2)) \end{array}$$

Example 5: Middleground network of array structure in *Reflections* (mm. 83–178).

To reduce the structure one more level, I shall denote §1 and §2 to represent the pc arrays for sections 1 and 2 of the piece respectively, as given in Equations 5 and 6:

$$\text{Eq. 5} \quad \S 1 \equiv (T_0(A1), RI_5(A1), I_{11}(A1), R_6(A1), T_0(A1), RI_5(A1))$$

$$\text{Eq. 6} \quad \S 2 \equiv (T_0(A2), RI_5(A2), I_{11}(A2), R_6(A2), T_0(A2), RI_5(A2))$$

From m. 179 to the end of the piece, Babbitt juxtaposes I11 transformations of ordered structures §1 and §2, which yields the formal structure shown in Example 6.

$$\begin{array}{ccc} \text{measure:} & 1 & 83 & 179 \\ \text{section:} & (\S 1, & \S 2, & \left[\begin{array}{c} I_{11}(\S 2) \\ I_{11}(\S 1) \end{array} \right]) \end{array}$$

Example 6: Middleground network of array structure in *Reflections*.

The transformations employed at the middleground level are once again restricted to the coset of four hexachordal-combinatorial operators and the subgroup of four hexachordal-invariance operators for type A hexachords, $S^{-1}=\{T_0, I_5, R_6, RI_{11}\}$ and $S=\{T_6, I_{11}, R_0, RI_5\}$ respectively. As in *Duet*, this achieves compositional unity on the middleground structure while simultaneously exercising the concept of maximal diversity on the foreground; in this piece Babbitt manages to circulate through all forty-eight row forms four times at the foreground level. Moving toward the background, the algebraic model I offer for the structure of *Reflections* is provided in Example 7.

$$\begin{array}{l}
 ((T_0(A1), RI_5(A1), I_{11}(A1), R_6(A1), T_0(A1), RI_5(A1)), \\
 (T_0(A2), RI_5(A2), I_{11}(A2), R_6(A2), T_0(A2), RI_5(A2)), \\
 I_{11} \left[\left[\begin{array}{l} (T_0(A2), RI_5(A2), I_{11}(A2), R_6(A2), T_0(A2), RI_5(A2)) \\ (T_0(A1), RI_5(A1), I_{11}(A1), R_6(A1), T_0(A1), RI_5(A1)) \end{array} \right] \right] \Big) \\
 \quad \blacksquare \quad (\{A1\} \circ \{T_0, I_{11}, R_6, RI_5\}, \\
 \quad \quad \{A2\} \circ [\{T_0, I_{11}, R_6, RI_5\}, \\
 \quad \quad \{A1, A2\} \circ \{\{T_0, I_{11}, R_6, RI_5\} \cup \{T_6, I_5, R_0, RI_{11}\}]) \\
 \quad \blacksquare \quad \{A1, A2\} \circ [\{T_0, I_{11}, R_6, RI_5\} \cup \{T_6, I_5, R_0, RI_{11}\}] \\
 = \quad \{A1, A2\} \circ \{T_0, T_6, I_5, I_{11}, R_0, R_6, RI_5, RI_{11}\} \quad \text{(from eq. 1)} \\
 = \quad \{A1, A2\} \circ [S \cup S^{-1}] \\
 \hspace{15em} \textit{Background}
 \end{array}$$

Example 7: Analytic model of *Reflections* at successive reductional levels.

At this point the need for levels of abstraction begins to come into better focus, for if I were to attempt to interpolate this middleground structure into a shallower middleground and eventually to the foreground structure — which was originally provided in the Peel and Cramer analysis — the level of complexity would render the model ineffective.¹⁵

Further analysis of the pitch structure in *Reflections* concerning the inter-relatedness of individual row forms within A1 and A2 or between A1 and A2 have yielded inconclusive results, or more correctly, have generated subgroups of operators that do not allow for the tidy analytical models based on the subset invariance theorem that I have been developing thus far. This does not mean that these relationships are uninteresting, but since they are tangential to the correlation between pitch structure and the subset invariance theorem, I need not explore them further here.

¹⁵I need to begin with the foreground analysis in order to extract the middle- and background structures — my analytical methodology must start with the surface pc's and unidirectionally move toward the background algebraic model.

Superarray Structures

Soli e Duettini for Two Guitars (1989), the first in a series of three pieces that all share the title *Soli e Duettini*, is an example of Babbitt's most recent compositional practice of using nested array structures to produce what several scholars have described as superarray structures.¹⁶ To date, the analytic literature for these three particular pieces is confined to a brief discussion of their large-scale superarray design in the closing pages of the final chapter in Andrew Mead's recent study of Babbitt's music.¹⁷

The twelve-tone row for the piece for two guitars, <0546te293187>, derives from a type D, second order all-combinatorial hexachord which is hexachordally combinatorial when integrated with the coset of canonical operators, $\{T_3, T_9, I_5, I_{11}, R_0, R_6, RI_2, RI_8\}$ and hexachordally invariant when combined with the subgroup of canonical operators $\{T_0, T_6, I_2, I_8, R_3, R_9, RI_5, RI_{11}\}$.¹⁸

The basic array for *Soli e Duettini* is based on a 6-lyne, 8-block, 58-partition array which incorporates each one of the 58 unique partitioning patterns of 6 lynes as well as all 48 distinct forms of the twelve-tone row once and only once.¹⁹ The basic array for guitar 1 is a T_6 transformation of the array used for the violin part in *The Joy of More Sextets* while the basic array for guitar 2 is an M_7R_4 transformation of the basic array used for guitar 1.²⁰ Table 4 provides the transformation network which structures the foreground pc array for guitar 1.

¹⁶The other two pieces are *Soli e Duettini for Guitar and Flute* (1989) and *Soli e Duettini for Violin and Viola* (1990). In *An Introduction to the Music of Milton Babbitt*, 204, Andrew Mead points out that many of the pieces from Babbitt's third period, beginning with *Ars Combinatoria* (1981), incorporate superarray strategies.

¹⁷Ibid., 255–63.

¹⁸Recall from the discussion of the subset invariance theorem in the first section of this paper that a type D hexachord is one of the six all combinatorial hexachords defined by Babbitt. Specifically, this type is a second-order, all-combinatorial hexachord which has the Forte set-class label 6–7, its prime form is (012678) and its interval-class vector is <420243>. Notice that the value for n in the subset invariance theorem is similar to that of the type A hexachord used in *Reflections* with some modifications to accommodate the tritone symmetry inherent in the second-order all-combinatorial type D hexachord. To begin let $n=11$, as is the case in the subgroup for the type A hexachord from the original theorem (see Table 1), but modify the subgroup to read $\{T_0, I_{n+3}, R_3, RI_n\}$. Next, combine the subgroup with the coset $\{T_6, I_{n+9}, R_9, RI_{n+6}\}$, produced via a T_6 transformation on the subgroup itself, yielding the total hexachordal invariance subgroup $S^{-1}=\{T_0, T_6, I_{n+3}, I_{n+9}, R_3, R_9, RI_n, RI_{n+6}\}$. Re-mapping the hexachordal pc invariance subgroup via the T_3 operator onto the coset, $S=\{T_3, T_9, I_n, I_{n+6}, R_0, R_6, RI_{n+3}, RI_{n+9}\}$, will produce the hexachordal combinatorial operators for the type D hexachord. These modifications account for the difference between the type A hexachord which is accurately described as a 6-pc chromatic cluster and the type D hexachord which may be best characterized as two disjunct 3-pc chromatic clusters a tritone apart.

¹⁹Ibid., 271. Mead describes the array for *Soli e Duettini* as being the same form as the array used for the solo violin part in *The Joy of More Sextets*, which is provided on pages 278–79.

²⁰ M_7 is the multiplicative operator which maps a given row form onto its circle-of-fifths transform. To generalize the multiplicative operator using the same format as the generalized models of the four canonical operators: Let X be the set of all rows; Let $X_y=(x_1, x_2, \dots, x_{12}) \in X$; Define the transformation on X: $M_n: X \rightarrow X$, where $M_n(X_y)=(n \cdot x_1, n \cdot x_2, \dots, n \cdot x_{12}) \bmod 12$.

Block 1	Block 2	Block 3	Block 4	Block 5	Block 6	Block 7	Block 8
I_8	RI_5	P_4	R_1	P_{10}	RI_{11}	I_2	R_7
P_7	R_4	I_{11}	RI_8	I_5	R_{10}	P_1	RI_2
I_9	P_{11}	R_2	RI_0	R_8	P_5	I_3	RI_6
R_5	RI_3	I_0	P_2	I_6	RI_9	R_{11}	P_8
R_6	I_7	R_3	RI_4	P_9	I_1	R_0	RI_{10}
P_6	RI_7	R_9	I_{10}	R_3	RI_1	P_0	I_4

Table 4: Row form array for guitar 1 in *Soli e Duettini*.

As in our previous analysis, the lynes of the array are grouped into hexachordally combinatorial pairs. Unlike the lyne pairs in the array used in *Reflections* which all shared the same transformational operator for their combinatorial pairings, each of the lyne pairs in this array has a unique transformational operator to effect hexachordal combinatoriality. The upper lyne pairs are related by I_5 or I_{11} , the middle lyne pairs by RI_2 or RI_8 , and the lower lyne pairs by R_0 or R_6 . If we group these six operators in a set along with T_3 and T_9 , which are the two operators that allow us to map transpositionally the first hexachord of the row onto the second, we produce the coset of hexachordally combinatorial canonical operators for a type D hexachord, $S = \{T_3, T_9, I_5, I_{11}, R_0, R_6, RI_2, RI_8\}$.

Referring back to Table 4 for a moment, let the column of row forms which comprise Block 1 be called A, such that

$$\text{Eq. 7} \quad A = \{ I_8, P_7, I_9, R_5, R_6, P_6 \} \equiv (\{ P_6 \} \otimes \{ I_5, I_{11}, R_0, R_6, RI_2, RI_8 \})$$

We can now follow the temporal progression of lyne pairs through the array at a deeper structural level by inspecting the linear network of transformational operators which operate on A, as shown in Example 8.

Block 1	Block 2	Block 3	Block 4	Block 5	Block 6	Block 7	Block 8
$(T_0(A), R_9(A), I_8(A), RI_5(A), I_2(A), R_3(A), T_6(A), RI_{11}(A))$							

Example 8: Middleground network of simple-array structure in *Soli e Duettini*.

As was the case in the previous two analyses, the network of horizontal transformations consists exclusively of the subgroup of canonical operators which produce hexachordal invariance, $S^{-1} = \{T_0, T_6, I_2, I_8, R_3, R_9, RI_5, RI_{11}\}$.

Moving yet another level deeper in the structure of this piece, the partitioning strategy for the superarray is based on a series of alternating duets and solo passages which are delineated by the eight blocks of the basic arrays for the two guitars forming a ten-block superarray. Andrew Mead diagrams the superarray structures for all three pieces titled *Soli e Duettini* and lines them up for comparison.²¹ Following Mead, I have labelled the blocks in guitar 1's basic

²¹Mead, *An Introduction to the Music of Milton Babbitt*, 256.

array from 1 to 8 and the blocks in guitar 2's basic array from 8 to 1 to reinforce the retrograde relationship between the two basic arrays as shown in Example 9. I have added the measure numbers and superarray block numbers above Mead's diagram for clarity.

Measure no.:	1	49	76	106	129	159	182	214	245	272
Super Block:	1	2	3	4	5	6	7	8	9	10
guitar 1:	(1	2	3	–	4*	5	6	–	7	8*
guitar 2:	(8*	–	7	6	5	–	4*	3	2	1)

Example 9: Block analysis of superarray structure in *Soli e Duettini*.

Blocks from the basic arrays marked with an asterisk contain an extra vertical aggregate to accommodate the partitioning strategy, therefore Babbitt is forced to work with unequal rates of aggregate completion between the two guitar parts in the first, third, fourth and sixth duets (i.e., superarray blocks 1, 5, 7, and 10). In the second and fourth duets, Babbitt maintains a consistent one to one aggregate correspondence between the two parts. By combining Examples 8 and 9 we are able to algebraically model the middle- and background pitch structure as shown in Example 10 below.

Middleground

$$\begin{aligned} & \left[\left(T_0(A), R_9(A), I_8(A), -, RI_5(A), I_2(A), R_3(A), -, T_6(A), RI_{11}(A) \right) \right. \\ & \left. \left(M_7I_3(A), -, M_7R_{10}(A), M_7T_7(A), M_7RI_6(A), -, M_7I_9(A), M_7RI_0(A), M_7T_1(A), M_7R_4(A) \right) \right] \\ & = \left[\left(\{A\} \circ \{T_0, T_6, I_2, I_8, R_3, R_9, RI_5, RI_{11}\} \right) \right. \\ & \left. \left(M_7R_4(\{A\} \circ \{T_0, T_6, I_2, I_8, R_3, R_9, RI_5, RI_{11}\}) \right) \right] \end{aligned}$$

from eq. 7

$$\begin{aligned} & = \left[\left(\{P_6\} \circ \{I_5, I_{11}, R_0, R_6, RI_2, RI_8\} \circ \{T_0, T_6, I_2, I_8, R_3, R_9, RI_5, RI_{11}\} \right) \right. \\ & \left. \left(\{P_6, M_7R_4(P_6)\} \circ \{I_5, I_{11}, R_0, R_6, RI_2, RI_8\} \circ \{T_0, T_6, I_2, I_8, R_3, R_9, RI_5, RI_{11}\} \right) \right] \end{aligned}$$

from eq. 1

$$\begin{aligned} & = \{P_6, M_7R_4(P_6)\} \circ [\{I_5, I_{11}, R_0, R_6, RI_2, RI_8\} \cup \{T_0, T_6, I_2, I_8, R_3, R_9, RI_5, RI_{11}\}] \\ & = \{P_6\} \circ \{T_0, M_7R_4\} \circ [S \cup S^{-1}] \end{aligned}$$

Background

Example 10: Analytic model of *Soli e Duettini* at successive reductional levels.

In the middleground equation guitar 1 is the upper portion of the expression and guitar 2 the lower. The dashed lines (–) in the shallow middleground expression represent the places where the respective guitar parts are silent in the ten-block superarray structure.

It should be evident at this point that the iterative quality of nested arrays does not significantly alter the deep level structure as Babbitt moves from a simple serial structure through to a superarray design. In fact, in each of the three analyses in this paper the background model has been based on a single row form or coset of row forms composed with the set theoretic union of the transformational operators that produce hexachordal combinatoriality (S) and hexachordal invariance (S⁻¹). The main difference between the simple serial structural model and the superarray structural model is the inclusion of the transformational operator that generates the other forms of the basic array into the equation.

Conclusion

Before I close, I would like to offer the following postulate: Given a twelve-tone row based upon an all-combinatorial hexachord that lacks a tritone in its ic-vector, the potential subgroup of operators that can generate maximal diversity while maintaining maximum internal structural coherence would be defined according to the subset invariance theorem (as worked out in Table 1) and the resultant group would manifest itself on the surface through the exploitation of hexachordally combinatorial pairings of row forms, even if the partitioning strategy did not favour hexachords.

I will not attempt to prove this postulate here, but based on the analyses I have completed thus far, I am persuaded that these are reasonable statements to make. Moreover, I believe further queries along these lines will yield results that would both strengthen and expand my current analytical model. Like many others, I believe that the richly varied surface texture of Babbitt's work distracts the listener from recognizing the inherent formal unities that structure deeper levels of his music. I do not believe that this fact alone prevents the informed listener or interpreter from detecting, at least subconsciously, the underlying formal unities in this repertoire, but it certainly requires a reassessment of the listening process and toward that end, new methods of dealing with the surface of this music. More directly, the rich and varied textures that mark the surface of Babbitt's twelve-tone compositional practice often seem to obstruct or block simpler underlying structures. Nevertheless, just as we tolerate and enjoy the complex strategies that underlie tonal structural levels, we need to make an equally strong effort to come to grips with the intricacies of Babbitt's extended serial compositions.

Appendix

1. Notational conventions

A, B	mathematical sets
$A \cup B$	union of sets A and B
$a, b \in A$	a and b are members of set A
{a, b}	unordered set consisting of elements a and b
(a, b)	ordered set consisting of a followed by b
a^{-1}	inverse of a with respect to a given operation
$a \equiv b$	a is abstractly equivalent to b
$a \approx b$	a approximately equivalent to b

$\Upsilon:A\rightarrow B$ operation Υ on A maps A onto B
 $\Lambda\Omega:A\rightarrow B$ the application of operation Ω to A and then Λ to the result of the first operation onto B , called the composition of maps Ω and Λ .

2. Twelve-tone row forms

$X_y=(x_1, x_2, \dots, x_{12})$, an ordered 12-tuple which exhibits the following properties:

- i) the 12 entries of X_y consist of all the integers from 0 to 11;
- ii) $X_y \in \{P_y, I_y, R_y, RI_y\}$ where $0 \leq y \leq 11$, and
 - P_y Prime row form label beginning with pc y
 - I_y Inversion row form label beginning with pc y
 - R_y Retrograde row form label ending with pc y
 - RI_y Retrograde Inversion row form label ending with pc y

3. Canonical operators

To define the four canonical operators (i.e., transposition (T), inversion (I), retrograde (R), and the composite operator retrograde-inversion (RI)):

Let X be the set of all rows (i.e., all permutations of the integers 0 to 11);

Let $X_y=(x_1, x_2, \dots, x_{12}) \in X$;

Define the following transformations on X :

$$T_n: X \rightarrow X, \text{ where } T_n(X_y) = (x_1+n, x_2+n, \dots, x_{12}+n) \text{ mod } 12$$

$$I_n: X \rightarrow X, \text{ where } I_n(X_y) = (n-x_1, n-x_2, \dots, n-x_{12}) \text{ mod } 12$$

$$R_n: X \rightarrow X, \text{ where } R_n(X_y) = (x_{-1 \text{ mod } 13}+n, x_{-2 \text{ mod } 13}+n, \dots, x_{-12 \text{ mod } 13}+n) \text{ mod } 12 \\ = (x_{12}+n, x_{11}+n, \dots, x_1+n) \text{ mod } 12$$

$$RI_n: X \rightarrow X, \text{ where } RI_n(X_y) = (n-x_{-1 \text{ mod } 13}, n-x_{-2 \text{ mod } 13}, \dots, n-x_{-12 \text{ mod } 13}) \text{ mod } 12 \\ = (n-x_{12}, n-x_{11}, \dots, n-x_1) \text{ mod } 12$$

4. Definitions

Definition 1:²² A mathematical group (G, \circ) consists of a non-empty set of abstract objects, G , and a binary operator, \circ , defined on the elements of G which have the following properties:

- i) closure: $x \circ y \in G$ for all $x, y \in G$;
- ii) associativity: $(x \circ y) \circ z = x \circ (y \circ z)$ for all $x, y, z \in G$;
- iii) identity: there exists an element $e \in G$, such that $x \circ e = e \circ x = x$, for all $x \in G$;
- iv) inverse: for all $x \in G$, there exists an $x^{-1} \in G$, such that $x^{-1} \circ x = x \circ x^{-1} = e$.

Definition 2: Z_n is a cyclic group which consists of a set of n integers $\{0, 1, \dots, n-1\}$, together with the binary operation of mod n addition, such that the equation $i+j=k \pmod{n}$ is always satisfied for any 2 integers $i, j < n$ and their integer sum $k \pmod{n} < n$.

Definition 3: D_m is a dihedral group of order $2m$ which is isometric under rotation, translation or reflection. The specific case of D_2 can be thought of as the non-cyclic group of order 4 which is generated by the cross product of $Z_2 \times Z_2$ which is a specific

²²Based on definitions and theorems from H.A. Elliot, K.D. Fryer, J.C. Gardner and Norman J. Hill, *Vectors, Matrices and Algebraic Structures* (Toronto: Holt, Rinehart and Winston, 1980), 367–407; and Derek J. S. Robinson, *A Course in the Theory of Groups*, Graduate Texts in Mathematics, no. 80, ed. J.H. Ewing, F.W. Gehring and P.R. Halmos (New York: Springer Verlag, 1991), 1–42.

direct product group known as the Klein-4 group in geometrical group theory (after nineteenth-century mathematician Felix Klein).

Definition 4: $D_m \times Z_n$ is a direct product group generated by the cross product of D_m with Z_n , and has order $2mn$.

Definition 5: Any given subset of a group which remains closed under the parent group's binary operation is referred to as a semi-group. The semi-group will exhibit some of the same structural characteristics as the parent group, but may lack either the identity property or the inverse property or both properties of the parent group. If the subset of the group also lacks the closure property under the parent group's binary operation, the subset is referred to as a coset.

Definition 6: If S is defined as a coset of $D_2 \times Z_{12}$, and S represents the unordered set of canonical operations that result in hexachordal combinatoriality for a given twelve-tone row, then we shall recognize its inverse, $S^{-1} = T_6(S) \equiv D_2$, a subgroup of $D_2 \times Z_{12}$ that represents the unordered set of canonical operations that result in hexachordal invariance for the same twelve-tone row.

Subset Invariance Theorem: for any group G which permutes elements of some ordered set U , there exists a non-trivial subgroup H which fixes the content of some non-trivial subsegment S of U , while permuting its elements.

Definition 7: Lyne is analogous to a monophonic interpretation of a linear series of pc sets or row forms.²³ In Babbitt's music, lynes are usually distinguished by register, dynamic, rhythmic pattern, articulation, orchestration, or any combination of the above.

Definition 8: An array is an abstract combination of two or more simultaneous horizontal row forms or lynes which can be partitioned into columns that form vertical aggregates.²⁴ Babbitt incorporates several important classes of arrays into his compositional language including trichordal arrays, all-partition arrays and superarrays (i.e., arrays of arrays).²⁵

Abstract

The unfolding of a compact algebraic group into a larger structure which exhibits an isomorphic relationship with the smaller group is the essence of "self-similarity." Through the use of transformational networks which take advantage of the group properties of the forty-eight canonical operators and through the examination of the hexachordally combinatorial properties of Babbitt's row forms, this paper examines the manner in which Babbitt selects and combines rows to produce maximal diversity on the surface while optimizing internal coherence at the deeper structural levels. This study focuses on three works that cover straightforward serial structures, simple array structures and superarray structures respectively — Babbitt's three main compositional strategies.

²³The term "lyne" is introduced by Michael Kassler in "Toward a Theory That Is the Twelve-Note-Class System," *Perspectives of New Music* 5, no. 2 (1967): 1–80.

²⁴The term "array" was first used by Godfrey Winham in "Composition with Arrays," *Perspectives of New Music* 9, no. 1 (1970): 43–67.

²⁵It is beyond the scope of this paper to provide generalized models of these array classes. The interested reader can refer to Andrew Mead, *An Introduction to the Music of Milton Babbitt* for a detailed description of these various types of arrays and analyses of Babbitt's idiomatic strategies for incorporating these arrays into his music. Mead loosely divides Babbitt's career into three creative periods, each marked by an affinity for a particular array class: 1947–60, trichordal arrays; 1961–80, all-partition arrays; 1981–present, superarrays.