

# On the Marginal Functions and Features of Object Clitics, with Special Reference to Modern Greek

Nick Bibis

Volume 28, Number 1, 2000

Traits et interfaces

URI: <https://id.erudit.org/iderudit/603187ar>

DOI: <https://doi.org/10.7202/603187ar>

[See table of contents](#)

Publisher(s)

Université du Québec à Montréal

ISSN

0710-0167 (print)

1705-4591 (digital)

[Explore this journal](#)

Cite this article

Bibis, N. (2000). On the Marginal Functions and Features of Object Clitics, with Special Reference to Modern Greek. *Revue québécoise de linguistique*, 28(1), 73–89. <https://doi.org/10.7202/603187ar>

Article abstract

Written within the minimalist program approach to grammar (Chomsky 1995), this paper examines the nature of  $\theta$ -role requirements in three types of object clitic constructions: *idiomatic* and *affected accusative* in Modern Greek, and *affected dative* in Modern Greek and French. I do not treat the idiomatic clitic constructions as lexically listed VPs, but as being derived syntactically. Furthermore, I argue that these constructions contain Tense and Person intrinsic features that are not visible to the syntax, and an obligatory  $\theta$ -feature [EXPERIENCER] checked in the syntax by means of the operation Attract-F. Affected accusatives are analyzed as non-A-bound  $\theta$ -marked affixes which attract an interpretable  $\theta$ -feature [EXPERIENCER] associated with V. A simple VP syntactic structure without clitic movement is attributed to them. Lastly, for affected dative constructions, I propose a  $v$  shell syntactic structure with base-generation of the clitic.

## ON THE MARGINAL FUNCTIONS AND FEATURES OF OBJECT CLITICS, WITH SPECIAL REFERENCE TO MODERN GREEK\*

Nick Bibis  
University of Toronto

### 1. Introduction

It is certainly no exaggeration to say that, in the generative tradition, the last twenty-five years have been marked by a proliferation of works dealing with recoverable, or argument-related, pronominal clitics.<sup>1</sup> Considering the enormous interest in this type of elements, very little attention has been paid to non-recoverable or non-argument-related clitics; see among a handful of works, for example, those of Authier and Reed 1992, Bibis 1999, Joseph 1990 and Ossipov 1995.

In this paper, I explore the grammatical distribution of what I term 'marginal' functions of the object clitic paradigms of Modern Greek (henceforth MGR) and French (henceforth FR). The constructions examined contain:

1° purely idiomatic [+ID] clitics found in the colloquial variety of MGR, and exemplified in (1 and 2):

---

\* This article has benefited from presentations at the University of Western Ontario's Workshop on Features (1998), the University of Ljubljana's 32<sup>nd</sup> Annual Meeting of the *Societas Linguistica Europaea* Workshop on Pronouns in Generative Grammar (1999), the University of Sherbrooke's Annual Meeting of the Canadian Linguistics Association (1999), and from conversations with Anne-Marie Brousseau, Diane Massam, Mihaela Pirvulescu, Yves Roberge, Marie-Thérèse Vinet, and from comments and suggestions by two anonymous *RQL* reviewers. Naturally, all responsibility for any remaining errors is mine.

1 Of the most important works, see, for example, Kayne 1975, Zwicky 1985, Jaeggli 1986, Philippaki-Warbuton 1993, Cummins and Roberge 1994, Bonet 1995, Sportiche 1996, Drachmann 1997 and Torrego 1998.

2 The reader may want to refer to Tsirpanlis's 1978 noteworthy inventory of Greek idioms for similar examples.

- (1) **tin** vrikame.  
 her-CL.F.ACC.3SG find-PAST.AOR.1PL  
 “We’ve enjoyed ourselves.”
- (2) **to** (e)vrase (gia ta kala).  
 it-CL.NTR.ACC.3SG boil-PAST.AOR.M/F.3SG (for the good)  
 “He/she is (really) late.”

2° affected accusatives found in the colloquial variety of MGR only, as in (3):

- (3) (O Yiannis) **me** koutsane.  
 (The-John-NOM) me-CL.M/F.ACC.1SG cripple-PAST.AOR.3SG.  
 “John was not of any help to me.”

and 3° affected datives as in (4) in MGR and (5) in FR:

- (4) O Yiannis **mou** kolise to pedi (krio).  
 The-John-NOM me-CL.M/F.DAT.1SG stick-PAST.AOR.3SG the-kid (cold-NP)  
 “John got my kid sick (with his cold).”

- (5) a. Jean **lui** a attrapé deux rhumes.  
 Jean him/her-DAT has caught two colds.
- b. ?? Jean a attrapé deux rhumes à Marie.  
 Jean has caught two colds to Marie  
 “Jean caught two colds on her.” (her = Marie).

Example (26) in Authier and Reed 1992

The main question which I examine is what type of lexical specifications one needs to attribute to the clitics exemplified in (1-5) above and by what principles this information is related to syntactic configurations. I propose that the syntactico-semantic contrasts between these three functional classes be analyzed both in terms of the clitic’s feature composition and of the level (i.e., the syntax or the lexicon; cf. for FR: Cummins and Roberge 1994; Bonnet 1995) at which the clitic is related to its host (i.e., a [ $\pm$ agentive] verbal head). I will show that all the clitic forms analyzed in this paper are syntactically derived.

Concerning clitic placement, I adopt Kayne’s 1987 premise that clitics are  $X^0$ s, may not adjoin to XPs, and certainly not directly to V, given that they can appear to the left of an auxiliary verb. Adopting Tsimpli’s 1990: 236 analysis of the MGR negative-indicative clause, I propose that the clitic element may merge with *default*  $T^0$ , interpreted by the operations at the LF interface always as [+Past]. In the case of a +ID clitic, it is imperative that it merge with  $T^0$ , which dominates AgrP; Nash and Rouveret 1998: 5 claim that “clitics are

exclusively merged [as arguments] in the functional domain” so that they satisfy an [arg]-feature of a given predicate L.

Regarding the analyses, +ID clitic constructions will not be treated in this paper as lexically listed phrasemes, i.e. VPs (cf. Jackendoff 1997). I hypothesize that these constructions involve a  $\theta$ -feature checked in the syntax and spelled out only at LF as part of a nominal expression (DP) occupying the external argument position of the verbal predicate; Manzini and Roussou 1998: 12-13 and Hornstein 1999: 78-9 consider  $\theta$ -roles to have a syntactic representation as formal features, although these authors arrive at this idea for reasons other than the ones I present here.

As for the intrinsic features of the predicative expression (see section 3.1 below), since these are lexically licensed, they need not be visible to syntactic rules but only to PF and LF interface operations. I claim that once these features become syntactically visible, configurational checking is triggered and the idiomatic reading of the predicate is blocked, thus giving rise to productive syntactic composition.

For the affected accusative clitics, a simple VP syntactic analysis is proposed, without clitic movement (section 4.1). As for the last case, the affected datives in MGR and FR, I propose a  $v$  shell syntactic analysis with base-generation of the clitic (section 4.2). Because these clitics are not assigned a  $\theta$ -role, by virtue of being in a ( $\theta$ -) chain with an (internal) argument position, the clitic head will necessarily attract an interpretable  $\theta$ -feature, namely interpretable [EXPERIENCER] or [PATIENT], thus the term *affected* in “affected datives”, associated with the verbal head.

## 2. Some observations and properties of the clitic forms *tin*, *to*, *ta*

In the case of +ID clitics we are dealing with a non-productive paradigm (see Table 1. below). Furthermore, it could be said that the +ID clitics constitute a subset of the –ID clitics paradigm. By this I mean that, of the full third person clitic paradigm presented in Table 1, only a few clitics can assume the function of +ID clitics.

Table 1  
Third Person + Idiomatic Clitics: *tin, din, di, to, ta*

PERSON	GENDER	NOM	GENDER	ACC	GENDER	DAT
t/d	MASC = <b>o</b>	s	o	n	∅	u
	FEM = <b>i</b>	∅	i	SG =(n) s	i	s
	NTR.SG = <b>o</b>	∅	o	∅	∅	u
	NTR.PL = <b>a</b>					

As such, and in contradistinction to the –ID clitic forms, +ID *tin, to, ta* cannot serve the function of recoverability but must serve other independently motivated functions. From a different angle, these forms do not conform to Sportiche’s 1996 Clitic Criterion, which states that at LF: 1° A clitic must be in a Spec-Head relationship with a [+specific] XP; 2° A [+specific] XP must be in a Spec-Head relationship with a clitic.

Note, then, that even though the label “clitic” is used throughout this paper, it is only for conventional reasons that I chose to do so. In fact, following Zwicky’s 1985 criteria, which help distinguish morphological affixes from clitic forms, one is dealing here with agreement markers or morphological affixes (Joseph 1990, Cummins and Roberge 1994).

I assume without discussion that, as a morphological affix, the clitic head is nothing else than a disguised functional head ‘Agr’<sup>3</sup> which, as far as the regular –ID clitic constructions are concerned, may, according to some analyses, adjoin to a X<sup>0</sup> element bearing finite Tense.<sup>4</sup> For us, the –ID clitic head, categorially a D, is found in the numeration, from where it is selected for computation.<sup>5</sup> However, in contradistinction to the traditional Agr functional head, which is devoid of any semantic content, this clitic head does not serve as an intermediary for Subject/Object–Verb agreement, as is the case for the Agr functional head, but for Nominal agreement (see section 3.1 for details).

3 See also Torrego 1998: 17, for whom the clitic “is similar but not identical to Agr<sub>0</sub>”.

4 See Anagnostopoulou 1997: 161, who claims that “despite the fact that clitic placement is very unclear, it is fairly straightforward that clitics end up being licensed in head positions (possibly an empty functional node above Agr<sub>0</sub>, Agr<sub>S</sub><sup>0</sup> or T<sup>0</sup>).”

5 In the case of a +ID clitic we are dealing with a head not specified for any particular categorial feature. This feature cannot be D for obvious reasons, D being locus of “referentiality” (Chomsky 1995). In fact this sort of clitic is devoid of any semantic features, so that it does not receive an interpretation at the LF interface.

We must recall the following facts of MGR (Alexiadou 1996): 1° Subject DPs never vacate the VP, and if they appear preverbally, then they are base-generated in a topic position, i.e. a Specifier of a Topic Phrase, behaving like dislocated elements moved from  $[\text{Spec}_1, v^{\text{max}}]$ ; 2° Nominative Case is a default Case, and as such need not be checked; and 3° the EPP feature is not strong. Then, for regular –ID clitics in finite clauses, as in example (6), I propose the representation (7), where the clitic is base-generated by adjunction not to  $T^0$  but to  $F^0$ , a placeholder functional projection head (Terzi 1999). Given that the verb raises only as high as  $T^0$  (no verb movement past  $F^0$  takes place), the clitic always surfaces to its left:

- (6) **tin** vrikame tin Maria.  
 her-CL.F.ACC.3SG find-PAST.AOR.1PL the-Maria-ACC  
 “We’ve found Mary.”

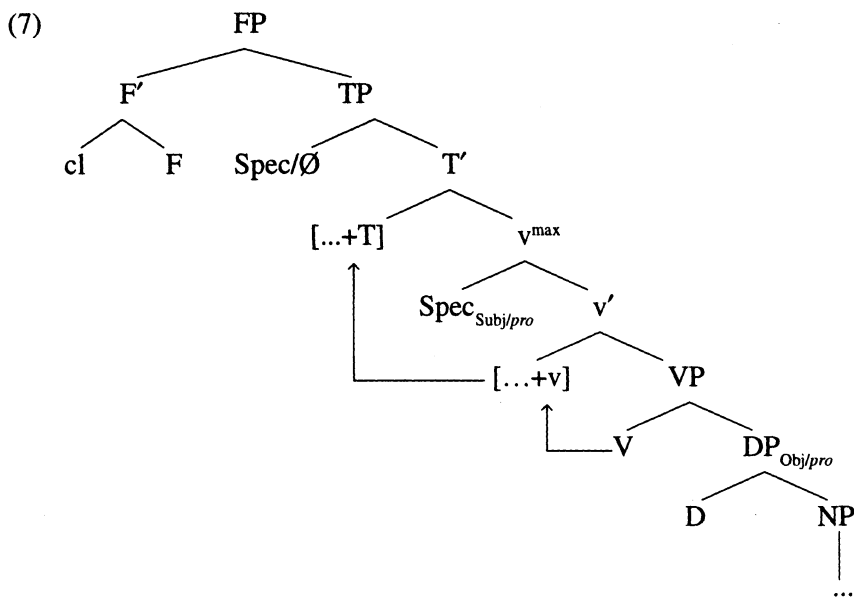

### 3. Non-argument related +ID clitic constructions

Expressions such as the one in (8) below can be best characterized as idiomatic if one takes idioms to be “fixed expressions that are semantically opaque, non-compositional, unanalyzable, or whatever other term one would like to use.” (Everaert et al. 1995: 4).

- (8) **tin** ekane.  
 her-CL.F.ACC.3SG make-PAST.AOR.3SG  
 "He/she left."

The problem one is faced with when dealing with the derivation of such expressions is readily identified by Jackendoff 1997: 153, who states that "[...] lexical insertion *substitutes* a lexical item for a terminal element (a lexical category or  $X^0$  category) in a phrase structure tree. Thus standard lexical insertion creates a problem for idioms, which do not look like  $X^0$  categories." Nevertheless, one can treat idioms as syntactic objects. This view brings up the research of Di Sciullo and Williams, for whom only elements inserted into an  $X^0$  position deserve the label syntactic atoms. On the other hand, listed syntactic objects are idioms "because of their failure to have a predictable property (usually their meaning)." (1987: 5). Accordingly, syntactic words are instances of  $X^0$ , and listed phrases are instances of  $X^{\max}$ .

Although I agree with these two authors on two crucial points (that listed phrases are instances of  $X^{\max}$  and that with idioms one cannot predict their compositional meaning), I do not treat the +ID clitic constructions as VPs listed in the lexicon for two reasons. First, there is an abundance of these constructions in MGR, so that listing all of them in the lexicon along with other language-particular idiosyncrasies would make for an awkward and uneconomical lexicon. A second reason is that these constructions are morphologically productive. What I mean by this is that the verb can appear in all persons and both numbers. Moreover, the noun occupying the subject position agrees with the verb. There are thus morphological requirements which I assume can only be satisfied if these constructions are syntactically derived.

These constructions have three interesting properties. First, one is not dealing, in examples such as (9), with a [+agentive] verbal predicate:

- (9) **tin** kopanisa.  
 her-CL.F.ACC.3SG [hit-PAST.AOR.1SG]-NON-AGENTIVE  
 "I am leaving."

Second, the thematic role of the predicate's external argument is, in the case of a [+Animate] noun in the subject position, that of [EXPERIENCER], as in (10) or, in the case of an [-Animate] noun, that of [THEME], as in (11); more discussion will follow.

- (10) **ta** bleksame.  
 [PRO-NOM.ANIM]-EXPERIENCER them-CL.NTR.ACC.3PL INVOLVE-PAST.AOR.1PL  
 "We are in a fine pickle."





as to license different effects at the interfaces, particularly at the LF interface, where the semantic interpretation of the literal or idiomatic reading of the constructions under investigation is taking place.

For this reason, I claim that the [+ID<sub>clitic</sub> +V] string will enter the computation carrying an invariable set of intrinsic formal features that will not need to be matched by other processes, namely checking in the syntax. The features in question are the following: *default* Tense<sup>7</sup>: [+Past]; phi-features of the +ID clitic: P(erson) [+3d], N(umber) [+/-SG], G(ender) [+FEM/+NTR], as in examples (1), (2). Among the features that must be checked are the  $\theta$ -feature [EXPERIENCER] or [THEME], which is interpretable at LF on the external argument head occupying the subject position, and the categorial feature V, Case assigned by T: [+NOM]; also, optional interpretable phi-feature for the [+ID<sub>clitic</sub> +V] string: [+/-A(nimate)], and agreement phi-features of V: PNG, as in examples (10), (11).

By *interpretable* features, I mean certain features of the FF(LI) (Formal Features of a Lexical Item), which enter into interpretation at LF: categorial features and phi-features of nouns.<sup>8</sup> On the other hand, uninterpretable features must be eliminated for convergence at LF. The Case features of V and T, as well as the agreement features of V, are among the uninterpretable features (Chomsky 1995: 277-278).

In such constructions there is no indirect  $\theta$ -marking, given that there is no V complement.  $\theta$ -role assignment should fail; then, it must nevertheless be achieved by other means in order for the derivation to satisfy legibility conditions at the LF interface. Here is where I introduce the notion of an obligatory Subject  $\theta$ -feature, an optional non-categorial feature of a lexical item which is determined relationally. First, note that the Subject DP will not be phonologically and semantically licensed in the same way that the [+ID<sub>clitic</sub> +V] string is. On semantic grounds, such a DP proves necessary in order to satisfy the argument structure of the idiom. Consequently, upon entering the numeration, it will be appropriately specified to match the interpretable  $\theta$ -feature, [EXPERIENCER] or [THEME], associated with the clitic, by means of Attract-F.

---

7 It is important to distinguish here between *default* and *defective* T. Defective T is found, for example, with imperatives (Terzi 1999). Considering that the cases of +ID clitic expressions examined in this paper cannot appear in imperative constructions and that the verb always appears in the [+Past] form, it seems that the T involved in these constructions would have to be different from the T involved in imperative constructions. It is for these two reasons that I claim that the T in +ID clitic expressions has the default status [+Past].

8 In recent work, Chomsky gives a more general definition of *Interpretable* features, where no direct mention to their purpose at the LF or PF interface levels is made. He says that "certain features of lexical items are *interpretable*, that is, legible to the external systems at the interface." (1998: 7)

It is in this sense that the +ID clitic constructions will entail a DP<sub>subject/pro</sub> clitic agreement. In other words, an overt nominal (DP) in the subject position or an empty category *pro* will be in an agreement relation, a theta-role agreement relation, with the +ID clitic. Analytically, the phi-features Person, Number, Gender, Animacy (PNGA) will be checked against those of the idiomatic predicate head which is obligatorily adjoined to Tense. The subject will move from its VP internal position. At [Spec, TP], it will attract the aforementioned interpretable  $\theta$ -feature.

According to Terzi 1999, the clitic in defective tense contexts is base-generated by adjunction to T<sup>0</sup>. In imperative and gerund clauses, the verb proceeds via T<sup>0</sup> overtly as a ‘by-product’ of its overt movement to a higher position in the clause (C<sup>0</sup> or M<sup>0</sup>). I propose a different derivation for idiomatic clitic constructions, which accounts for the +ID clitic placement. Note, though, that this derivation cannot be represented as in (13), given that Kayne’s 1994 LCA (Linear Correspondence Axiom) excludes multiple adjunction to the same head, here T<sup>0</sup>:

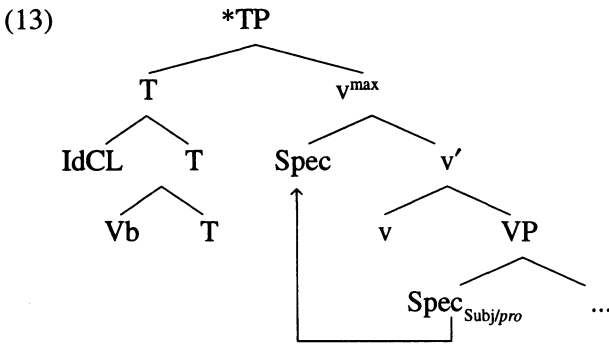

The correct, partial representation for example (1), repeated for convenience as (14), is given in (15):

- (14) **tin** vrikame.  
 her-CL.F.ACC.3SG find-PAST.AOR.1PL  
 “We’ve enjoyed ourselves.”



#### 4. A base-generation analysis for affected accusatives and datives

##### 4.1 Affected accusatives

I characterize as ‘affected’ the accusative clitic of example (3), repeated in (18), because, when it appears on certain verbal predicates, the individual it refers to is psychologically affected by the event denoted by the whole sentence.

- (18) (O Yiannis)      **me**                                  koutsane.  
 (The-John-NOM) me-CL.M/F.ACC.1SG cripple-PAST.AOR.3SG  
 “John was not of any help to me.”

Affected accusatives are not associated with *pro* or a lexical NP and cannot alternate with a full pronoun:

- (19) (O Yiannis)      koutsane                                  \*emena.  
 (The-John-NOM) cripple-PAST.AOR.3SG me-PRO.M/F.ACC.1SG  
 “John was not of any help to me.”

In this sense, affected accusatives are not A-bound clitics. Structurally and semantically speaking, they are closer to +ID clitic constructions than they are to regular argument-related (–ID) clitic constructions. Besides, they are not an integral part of a syntactically represented listed VP, given their morphologically productive character (see section 3 above).

In contradistinction to +ID clitics, affected accusatives are not implicated in the determination of the external  $\theta$ -role typically assigned (in the regular argument-related (–ID) clitic constructions, as in example (20)) by the predicate and the internal argument with which the clitic is coindexed:

- (20) I fitites                                  *tin<sub>i</sub>*                                  vrikane                                  *tin Maria<sub>i</sub>*.  
 The-students-NOM her-CL.F.ACC.3SG find-PAST.AOR.3PL the-Maria-ACC  
 “The students have found Mary.”

The fact that there is no V complement present in the derivation of the affected accusative constructions suggests that the verb alone should account for the licensing of the external  $\theta$ -role [AGENT] by means of Attract (hence Move)-F, where F is the  $\theta$ -feature having the value [AGENT]:

- (21) (O Yiannis)                                  **ton**                                  koutsane                                  \*ton Pavlo.  
 (The-John-NOM.AGENT) him-CL.F.ACC.3SG cripple-PAST.AOR.3SG the-Paul-ACC  
 (Expected reading: “John was not of any help to Paul.”).

The ungrammaticality of (21), or in other words the fact that there is no internal argument merged with V, calls for a simple VP syntactic structure with head (set-) merging of the clitic with V or T, depending on the morphology of the MGR verb ([+Past] or [+Present]). In the first case, Tense is higher than V and AgrS, so the clitic will appear to the left of the past tense morpheme<sup>9</sup>, as in (17) above. In the second case, the clitic will appear to the left of V which is higher than T.

Note that the clitic itself must bear a  $\theta$ -role, namely [EXPERIENCER] spelled out at the LF interface, given that the clitic's denotation is not the null set. There are two possible sources for this  $\theta$ -role, though this issue is subject to further research. Firstly, it could be postulated that the clitic is optionally assigned this  $\theta$ -role upon entering the numeration. Or, secondly, that the clitic, being of category D, attracts an interpretable  $\theta$ -feature [EXPERIENCER] associated with V.

#### 4.2 Affected datives

To use Authier and Reed's 1992: 28 definition, non-lexical datives always refer to an individual who is understood as being concerned in some "pragmatically determined way by the event denoted by the whole sentence." So in the FR example (5a) repeated here as (22), *Marie*, the individual referred to by the non-lexical dative *lui*, is concerned in some pragmatically determined way by the event denoted by the whole sentence.

- (22) Jean **lui** a attrapé deux rhumes.  
 Jean him/her-DAT has caught two colds.  
 "Jean caught two colds on her." (her = Marie).

Affected datives are subject to various morphosyntactic constraints. First, (5b), repeated as (23), demonstrates that FR affected datives do not easily alternate with a full dative NP:

- (23) ?? Jean a attrapé deux rhumes à Marie.  
 Jean has caught two colds to Marie.  
 "Jean caught two colds on her." (her = Marie).

This property is also shared by MGR affected datives, which can be justly termed 'non-lexical datives', since these clitics cannot be doubled:

<sup>9</sup> I assume here Ralli's 1998: 69-70 analysis of the MGR verb:

(1) elises < e li s es  
 past untie perfective 2<sup>nd</sup> person singular, past  
 "you untied."

- (24) O Yiannis      *mou<sub>i</sub>*                      kolise.                      \**emena<sub>i</sub>*  
 The-John-NOM me-CL.M/F.DAT.1SG stick-PAST.AOR.3SG me-PRO.M/F.ACC.1SG  
 to pedi  
 the-child-ACC  
 “John got my child sick (with his cold).”

Second, affected datives are not licit in sentences containing a pseudotransitive verb, that is a verb, such as *eat*, which can have both a transitive and an intransitive use:

- (25) O Yiannis      *tou*                      efaje                      \*(to tiri).  
 The-John-NOM him-CL.M.DAT.3SG eat-PAST.AOR.3SG (the-cheese-ACC)  
 “Yiannis ate (the cheese) (on him).”

Somehow, this constraint does not seem to apply cross-linguistically; in FR, affected datives can appear on such a verb as long as a locative or manner adjunct phrase is present within the VP:

- (26) Jean              *lui*                      a frappé                      l'enfant  
 The-John-NOM him-CL.M/F.DAT.3SG AUX hit-PARTICIPIAL the-child-ACC  
 sans pitié.  
 [without pity]-MANNER ADJUNCT  
 “John hit the child (which concerns him) without pity.”

Furthermore, this is to say that in FR a causal or temporal adjunct cannot license an affected dative (Authier and Reed 1992), whereas this is not so in MGR, where any type of adjunct, or no adjunct at all, can create a licensing environment for affected:

- (27) O Yiannis      *mou*                      efaje                      to tiri  
 The-John-NOM me-CL.M/F.DAT.1SG eat-PAST.AOR.3SG the-cheese-ACC  
 jiati pinaje.  
 [because hungry-PAST.3SG]-CAUSAL ADJUNCT  
 “John ate my cheese (on me) because he was hungry.”
- (28) O Yiannis      *mou*                      efaje                      to tiri.  
 The-John-NOM me-CL.M/F.DAT.1SG eat-PAST.AOR.3SG the-cheese-ACC  
 “John ate my cheese (on me).”

In sum, FR affected datives are licensed only when the highest projection of the verbal head to which they attach ( $V^{\max}$ ) contains material in addition to the head, whereas MGR affected datives can be licensed by lexical material that is outside  $V^{\max}$ , assuming, as Authier and Reed 1992 do, that temporal and causal adjuncts attach to IP, or to TP in minimalist terminology.

Third, another feature of these clitics, reported for FR by Authier and Reed 1992, is that they can be licensed by VP-internal Case assignment. In other words, if there is a referential adjunct that is assigned case by the preposition *with* that selects it, it is possible to spell out the affected dative *mou* on the verb:

- (29) O Yiannis        **mou**                    stenochorise        to pedi  
 The-John-NOM me-CL.M/F.DAT.1SG upset-PAST.AOR.3SG the child-ACC  
 me tin stasi tou.  
 [with DET attitude GEN]-REFERENTIAL ADJUNCT  
 "John upset the child (which concerns me) with his attitude."

However, as far as MGR and even English are concerned, this is an overstatement that needs to be relaxed because it does not rule out affected datives that appear on ergative verbs; it does so for FR, where such verbs do not assign Case to the derived subject; in that case the  $\theta$ -role associated with the clitic can no longer be available:

- (30) Tis                    pethane                    o antras.  
 Her-CL.F.DAT.3SG die-PAST.AOR.3SG the-husband-NOM  
 "Her husband died on her."  
 \*Son mari **lui** est mort.

- (31) Her husband died on **her**.

According to Authier and Reed 1992, affected datives are  $\theta$ -bearing affixes which are a reflection of the external  $\theta$ -grid of the highest VP-projection at D-structure. However, these two linguists are not so clear about the source of the  $\theta$ -role assigned to the affix. They propose two options, the second of which seems more promising: that the affix "introduces this theta-role directly instead of receiving it from the highest VP projection" (1992: 36).

It is clear from examples such as (22-24) that FR and MGR affected datives do not in any way correspond to an argument which is internal to the predicate. If this were true, one would then expect a change to occur with respect to the  $\theta$ -role assigned to the subject DP of a given sentence. In other words, the presence or absence of the clitic *mou* on the past verb *ktipise* does not trigger a difference with respect to the determination of the assigned external  $\theta$ -role:

- (32) O Yiannis                    **mou**                    ktipise                    to pedi.  
 The-John-NOM.AGENT me-CL.M/F.DAT.3SG beat-PAST.AOR.3SG the-child-ACC  
 "Yiannis beat the child (which concerns me)."

- (33) O Yiannis                    ktipise                    to pedi.  
 The-John-NOM.AGENT beat-PAST.AOR.3SG the-child-ACC  
 "Yiannis beat the child."

I attribute to affected dative constructions such as (32) a  $\nu$  shell syntactic structure which includes a VP headed by a [+agentive] light verb  $\nu$ . In this example, the subject DP *O Yiannis* is assigned its  $\theta$ -role [AGENT] by the light verb. Given that affected datives are not assigned a  $\theta$ -role by virtue of being in a chain with an argument position, they must rely on other means to ensure that no legibility violation arises at the LF interface. Assume again that, under such circumstances,  $\theta$ -roles are formal features. The transferring of the  $\theta$ -feature [EXPERIENCER] or [PATIENT] to the clitic *mou* is accomplished by the operation Attract-F. Suppose further that F is the uninterpretable  $\theta$ -feature of D (the clitic Syntactic Object (SO)). F, being the attractor, must then seek the matching feature F' of the light verb  $\nu$ , which is responsible for standard agreement in derivations where there are no projected AGR nodes for Subject or Object agreement. F must then attach/add it to SO containing the feature F, deleting F (i.e. respecting Suicidal Greed) and thus forming SO', the new syntactic object carrying the interpretable  $\theta$ -role feature [EXPERIENCER] or [PATIENT] of  $\nu$ . One last remark: in terms of clitic placement, these clitics may then move further up the tree, cliticizing to an argument-related clitic.

## 5. Conclusion

Although it is not empirically verifiable, for the time being and cross-linguistically, that one should dispense altogether with the Minimalist Program version of  $\theta$ -theory, it is in fact desirable in certain special cases, namely the ones examined in this paper, to argue for the syntactic representation of  $\theta$ -roles as formal features. I have examined the possibility of applying Checking theory in a novel way that allows blocking of the composed meaning of the +ID clitic constructions. As expected, my analyses were varied, given the particular properties of each case examined, especially the featural composition of the clitics. On another level, this has strengthened the notion of linguistic modularity: certain components of the generative model, in particular the Computational component and the LF interface, assume a greater role in the overall derivation of the constructions at hand.



## References

- ALEXIADOU, A. 1996 "Subject Positions in Modern Greek", in *Proceedings of the 16<sup>th</sup> Annual Meeting of the Department of Linguistics, Faculty of Philosophy, Aristotle University of Thessaloniki (4-6 May 1995)*, *Studies in Greek Linguistics* 16: 242-253.
- ANAGNOSTOPOULOU, E. 1997 "Clitic Left Dislocation and Contrastive Left Dislocation", in E. Anagnostopoulou, H. van Riemsdijk, and F. Zwarts (eds.), *Materials on Left Dislocation*, Linguistik Aktuell Series 14, Amsterdam, John Benjamins.
- AUTHIER, J.-M. and L. REED 1992 "On the Syntactic Status of French Affected Datives", *The Linguistic Review* 9-4: 295-311.
- BIBIS, N. 1999 "Modern Greek Object "Clitic" Pronouns in Idiomatic Contexts as Morphological Affixes", in *Proceedings of the 1998 Conference of the Canadian Linguistic Association*, Cahiers Linguistiques d'Ottawa, University of Ottawa.
- BONET, E. 1995 "Feature Structure of Romance Clitics", *Natural Language and Linguistic Theory* 13-4: 607-647.
- CHOMSKY, N. 1995 *The Minimalist Program*, Cambridge (Mass.), MIT Press.
- CHOMSKY, N. 1998 "Minimalist Inquiries: The Framework", *MIT Occasional Papers in Linguistics* 15, Department of Linguistics and Philosophy, MIT.
- CUMMINS, S. and Y. ROBERGE 1994 "A Morphosyntactic Analysis of Romance Clitic Constructions", in M.L. Mazzola (ed.), *Issues and Theory in Romance Linguistics: Selected Papers from the Linguistic Symposium on Romance Languages XXIII (April 1-4, 1993)*, Washington, Georgetown University Press.
- DI SCIULLO, A.-M. and E. WILLIAMS 1987 *On the Definition of Word*, Cambridge (Mass.), MIT Press.
- DRACHMANN, G. 1997 "Some Properties of Clitics (with Special Reference to Modern Greek)", in A. Alexiadou and T.A. Hall (eds.), *Studies on Universal Grammar and Typological Variation*, Amsterdam, John Benjamins.
- EVERAERT, M., E.-J. VAN DER LINDEN, A. SCHENK, and R. SCHREUDER 1995 "Introduction", in M. Everaert et al. (eds.), *Idioms: Structural and Psychological Perspectives*, Hillsdale (New Jersey), Lawrence Erlbaum Associates.
- HORNSTEIN, N. 1999 "Movement and Control", *Linguistic Inquiry* 30-1: 69-96.
- JACKENDOFF, R. 1997 *The Architecture of the Language Faculty*, Cambridge (Mass.), MIT Press.
- JAEGGLI, O. 1986 "Three Issues in the Theory of Clitics: Case, Doubled NPs, and Extraction", in H. Borer (ed.), *Syntax and Semantics 19: The Syntax of Pronominal Clitics*, New York, Academic Press.
- JOSEPH, B. 1990 "The benefits of morphological classification: on some apparently problematic clitics in Modern Greek", in W.U. Dressler, H.C. Luschützky, O.E. Pfeiffer, and J.R. Rennison (eds.), *Contemporary Morphology*, New York, Mouton de Gruyter.
- KAYNE, R. 1975 *French Syntax: The Transformational Cycle*, Cambridge (Mass.), MIT Press.

- KAYNE, R. 1987 "Null Subjects and Clitic Climbing", ms, MIT.
- KAYNE, R. 1994 *The Antisymmetry of Syntax*, Linguistic Inquiry Monographs 25, Cambridge (Mass.), MIT Press.
- MANZINI, M.R. and A. ROUSSOU 1998 "A Minimalist Theory of A-Movement and Control", ms, Florence/UCL-Bangor.
- NASH, L. and A. ROUVERET 1998 "Feature fission and the syntax of argument DPs and clitics", ms, Paris 8, Upresa 7023.
- OSSIPOV, H. 1995 "Un petit mot sur  $\gamma$ ", *Revue québécoise de linguistique* 24-1: 173-179.
- PHILIPPAKI-WARBURTON, I. 1993 "Verb Movement and Clitics in Modern Greek", in I. Philippaki-Warbuton, K. Nicolaidis, and M. Sifianou (eds.), *Themes in Greek Linguistics: Papers from the First International Conference on Greek Linguistics, (Reading, September 1993)*, Amsterdam, John Benjamins.
- RADFORD, A. 1997 *Syntactic Theory and the Structure of English: A Minimalist Approach*, Cambridge, Cambridge University Press.
- RALLI, A. 1998 "On the Morphological Status of Inflectional Features: Evidence from Modern Greek", in B.D. Joseph, G.C. Horrocks, and I. Philippaki-Warbuton (eds.), *Themes in Greek Linguistics II*, Amsterdam: John Benjamins.
- SPORTICHE, D. 1996 "Clitic Constructions", in J. Rooryck and L. Zaring (eds.), *Phrase Structure and the Lexicon*, Dordrecht, Kluwer.
- TERZI, A. 1999 "Clitic Combinations, their Hosts and their Ordering", *Natural Language and Linguistic Theory* 17: 85-121.
- TORREGO, E. 1998 *The Dependencies of Objects*, Cambridge (Mass.), MIT Press.
- TSIMPLI, I.-M. 1990 "The clause structure and word order in Modern Greek", *University College (London) Working Papers in Linguistics* 2: 226-255.
- TSIRPANLIS, C. 1978 *Modern Greek Idiom and Phrase Book*, New York, Barron.
- ZWICKY, A. 1985 "Clitics and Particles", *Language* 61: 283-305.