

A Small Circular Flume for Laboratory Studies on Particle Abrasion

R. A.G. Gees, B. Langhus and F. Medioli

Volume 6, Number 1, April 1970

URI: https://id.erudit.org/iderudit/ageo06_1rep04

[See table of contents](#)

Publisher(s)

Maritime Sediments Editorial Board

ISSN

0843-5561 (print)

1718-7885 (digital)

[Explore this journal](#)

Cite this article

Gees, R. A., Langhus, B. & Medioli, F. (1970). A Small Circular Flume for Laboratory Studies on Particle Abrasion. *Atlantic Geology*, 6(1), 15–16.

A Small Circular Flume for Laboratory Studies on Particle Abrasion*

R.A.G. GEES, B. LANGHUS and F. MEDIOLI
Department of Geology, Dalhousie University, Halifax, N. S.

In the course of our laboratory work on sedimentological and neontological problems we are often in need of a continuous flow flume. Equipment of this type is normally very bulky and expensive and therefore beyond the reach of most laboratories.

In the search for a suitable piece of equipment we came across a circular flume described by Kuenen (1955). His apparatus which was used in connection with experimental abrasion studies of pebbles is much too costly and bulky for our studies on abrasion of foraminiferal tests and sedimentary particles. We therefore decided to build a similar apparatus, less costly and lighter, with interchangeable flumes.

The first flume (Fig. 1) was built with ten feet 12" diameter "Bendaway" metal duct¹. The duct was bent into a circular shape similar to a giant doughnut, having an outside diameter of 110 cm. The upper third of the duct was cut off. The ends of the resulting circular trough were cemented together with epoxy resin.

The flume was subsequently painted inside and outside with epoxy paint in order to make it corrosion resistant². This was done because some of our tests are performed in natural sea water. The trough is mounted on a 48"x48" piece of 3/4" plywood braces.

The water flow, in the trough, is generated by two rotating paddles, which are mounted to a horizontal arm made of an angle bar of aluminum³. The bar is mounted to the shaft of an electric motor⁴. The paddles are secured to the angle bar by means of clamps. This mounting permits an easy adjustment of both the depth and the pitch of the paddles. For most of our experiments the paddles are kept perpendicular to the periphery of the trough, reaching about 1/2" into the water, and rotating with anywhere from 14 to 24 rpm. This corresponds to an average linear speed of approximately 2.6 to 4.5 Km/h or 1.4 to 2.4 knots. Lower speeds can be readily achieved by reducing the rpm of the motor by means of a powerstat⁵.

At the present time we are investigating the behaviour of empty tests of foraminifera to abrasion. This test will last for several months with samples retrieved at regular intervals. For this purpose we introduced a coarse calcareous sand into the trough. The desired movement i.e. saltation of the foraminiferal tests is achieved by properly adjusting the rpm of the paddles. In all a sample of 15 gr. of foraminiferal tests was introduced into the trough. Abrasion of the tests is investigated as a function of time. It would be more desirable to relate it to the distance of transportation, however we have as yet not been able to develop a method which would enable us to measure with some reliability the travelling distance of the particles under investigation.

In the future we intend to use the flume in connection with studies of surface textures of sedimentary particles, namely to test the concept of abrasion solution. For this purpose we intend to line the trough with water resistant sand paper. We are also considering the possibility of using this apparatus as a teaching aid in sedimentology. In order to make it more suitable for this purpose we are in the process of building a flat bottomed plexiglas trough. The cost of the material used for the construction of the flume is just over \$100.

References cited

KUENEN, Ph. H., 1956, Experimental abrasion of pebbles: Wet sand blasting. Leidse Geol. Mededel. 1955, 20: 131-137.

¹ The Flexaust Co., 227 Park Ave., New York, N.Y., 10017, U.S.A.

² Epoxy aluminum primer, Sears & Roebuck, Chicago, Ill., U.S.A.

³ 7"x10" paddles, 14 ga. aluminum.

⁴ Bodin Model NC 1 - 34 RHL, 28 rpm, 1/15 hp, AC, 5 Fd capacitor, equipped with worm gear. Bodin Electric Co., Chicago, Ill., U.S.A.

⁵ Powerstat type 116, 7 - 1/2 Amp., Superior Elect. Co., Bristol, Conn., U.S.A.

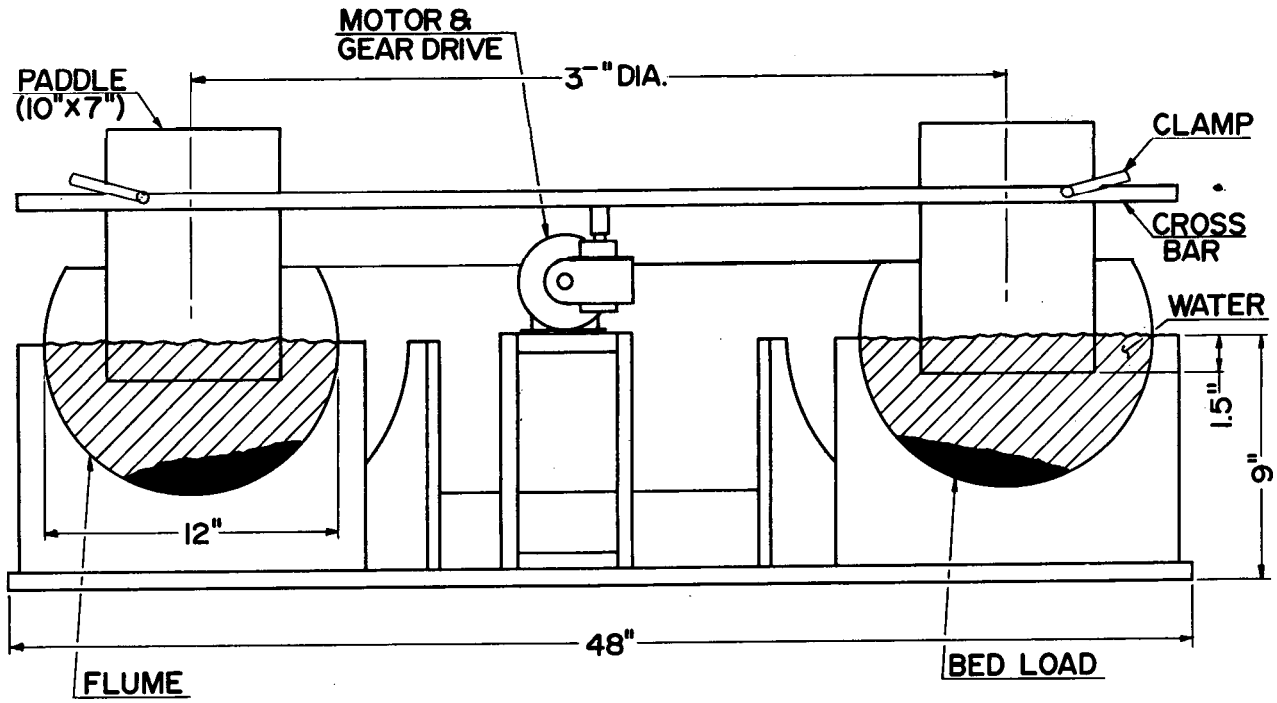

CROSS SECTION

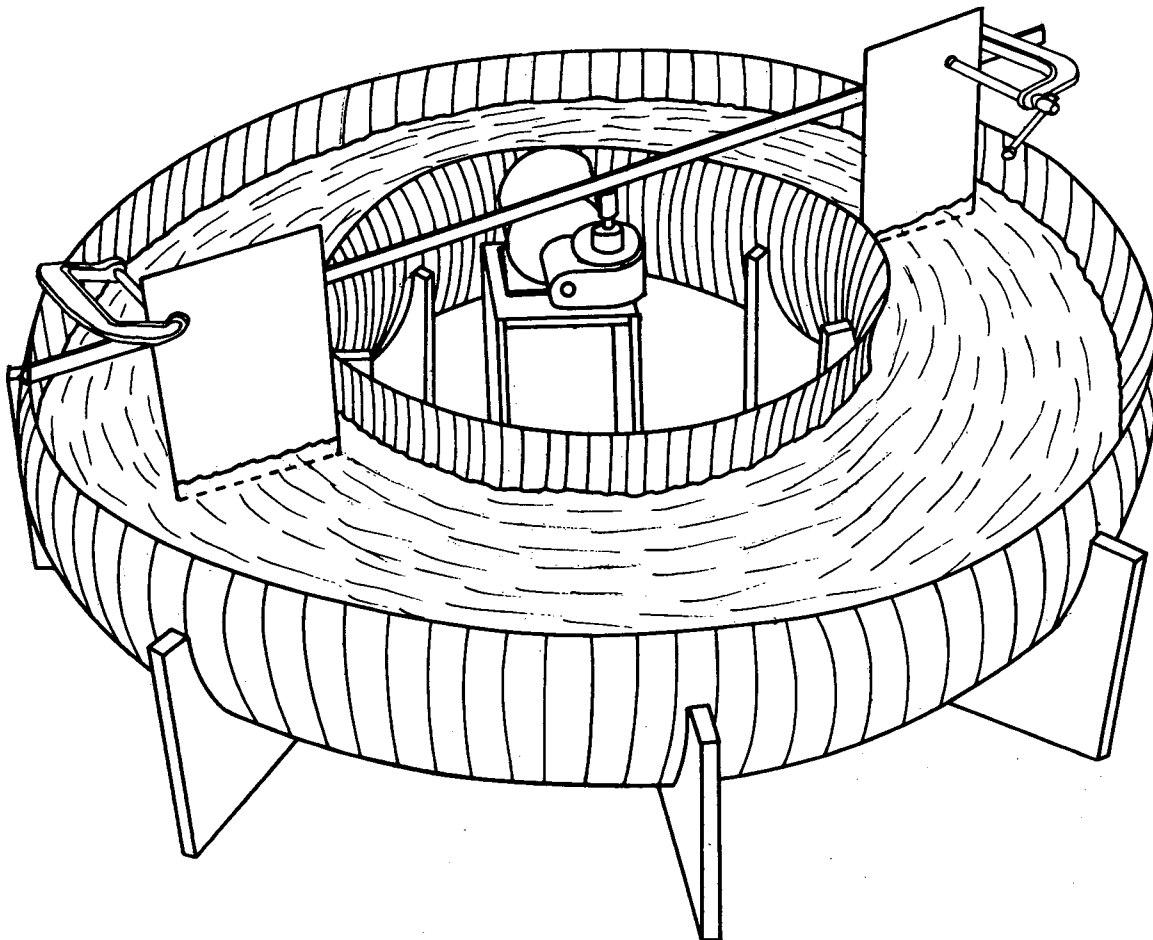

Figure 1 - Plan and cross-sectional views of circular flume.